



Track and Bridge Condition Assessment

ACRD Rail Corridor

Port Alberni Subdivision

Alberni-Clayoquot Regional District

June 16, 2025

Amendment:

November 19, 2025





Rev	Date	Revision Description	Prepared By	Reviewed By	Approved By
0	2025/06/16	Issued for Client Review	Diego Ruiz	Gary Chen/ Maryam Bostani	
1	2025/11/19	Added an amendment related to the bridge damage resulting from the July 2025 Wesley Ridge wildfire	Zahra Tavakoli	Fred Kramer	Fred Kramer
2					
3					



Disclaimer

In preparing this Report, HDR relied, in whole or in part, on data and information provided by the Alberni-Clayoquot Regional District (the Client) and third parties, which information has not been independently verified by HDR and which HDR has assumed to be accurate, complete, reliable, and current. Therefore, while HDR has utilized its best efforts in preparing this Report and supplemental information, HDR does not warrant or guarantee the accuracy of data, information or statements supplied by third parties or the Client.

Use of this Report or any information contained herein, if by any party other than Client, shall be at the sole risk of such party and shall constitute a release and agreement by such party to defend and indemnify HDR and its affiliates, officers, employees and subcontractors from and against any liability for direct, indirect, incidental, consequential or special loss or damage or other liability of any nature arising from its use of the report or reliance upon any of its content. To the maximum extent permitted by law, such release from and indemnification against liability shall apply in contract, tort (including negligence), strict liability, or any other theory of liability.

Prepared By:

Diego Ruiz, EIT
Name, Designation
Title

June 16, 2025
Date

Reviewed By:

Gary Chen, P.Eng.
Name, Designation
Title

June 16, 2025
Date

and

Maryam Bostani, PhD, P.Eng., PMP
Name, Designation
Title

June 16, 2025
Date

Amendment

Subsequent to the damage to four trestle bridges during the Wesley Ridge wildfire in July 2025, this amendment provides updated cost estimates for the bridges at Mile **13.7**, **13.8**, **14.0**, and **14.6**. The revised cost details for the affected structures are presented in the table below.

Table 1: Port Alberni Subdivision Bridge Replacement Cost

Mile	Featured Crossed	Total Length (ft)	Substructure	Current Status after wildfire	Steel Bridges Replacement Cost
13.7	Dry	209.5	Timber Frame Trestle	Completely burned	\$ 7.9 M
13.8	Dry	105	Timber Frame Trestle	Completely burned	\$ 3.9 M
14	Dry	225	Timber Frame Trestle	Significantly damaged beyond repair	\$ 8.5 M
14.6	Dry	441	Timber Frame Trestle	Significantly damaged beyond repair	\$ 16.6 M
Total cost					\$ 37 M
Contingency (50%)					\$ 18.6 M
Total Bridges Replacement Cost					\$ 55.6 M

Previous to this revision, the opinion of probable construction costs to upgrade the track infrastructure to support a 10-ton emergency hi-rail vehicle was approximately \$3,377,400 (including contingency). Given the replacement costs for the four bridges damaged or destroyed in the Wesley Ridge wildfire, the total amount is now estimated to be over \$50 million.

Executive Summary

The Alberni-Clayoquot Regional District (ACRD) retained HDR Corporation (HDR) to evaluate the condition of the track and bridges along the former E&N Railway Port Alberni Subdivision, extending from Parksville to Port Alberni. The rail corridor is owned by the Island Rail Corridor Foundation (ICF) but has not seen rail operations since 2001. The primary objectives were: to assess the feasibility of using the corridor for emergency access by a 10-ton hi-rail vehicle; provide an opinion of probable cost estimate for any repair of railway infrastructure; and to identify any further studies or infrastructure upgrades required to support 10-ton hi rail access. The track was divided into three segments for the purposes of the assessment: Parksville to McBey Creek (Mile 0.0 to 12.3); McBey Creek to Loon Lake (Mile 12.3 to 21.8); and Loon Lake to Port Alberni (Mile 21.8 to 39.4).

A field inspection of the track segments was conducted between May 12 – 14, 2025 by HDR and accompanied by Southern Railway of Vancouver Island (SVI), Island Corridor Foundation (ICF), and Tseshah First Nation (TFN). Access throughout the corridor, particularly in Segments 1 and 3, was significantly hindered by dense vegetation, fallen trees, and rockfall. Overall, the track was found to be in fair to poor condition, with widespread deterioration of ballast and ties considering the use of the corridor for emergency access to support a 10-ton hi rail vehicle. Several areas exhibited evidence of rockfall, and in some locations, embankment instability was observed. Only a few culverts were able to be located and confirmed to be functioning due to them being unmarked or unable to be located in the dense vegetation.

Clearing of fallen debris, vegetation, and obstructions is required to enable hi-rail access. This will allow for detailed evaluation of currently inaccessible segments and facilitate a focused geotechnical assessment of locations exhibiting rockslide activity or embankment failure. Previous to this revision, the opinion of probable construction costs to upgrade the track infrastructure to support a 10-ton emergency hi-rail vehicle is approximately \$967,750.

A field inspection of the bridges was conducted between May 12 – 14, 2025 by HDR and accompanied by SVI, ICF, TFN, and NovaForest Services Ltd. The bridge assessments were supported by drone imagery where possible and included reviews of the bridge decks, superstructures, and substructures. While most bridges were last inspected in 2019, four timber trestle bridges underwent more detailed evaluations in 2021. The majority of structures were found to be in fair condition, with the exception of the bridge at Miles 13.7, 13.8, 14.6, 18.1, 21.8, 25.0, and 29.9 that had various elements observed to be in poor condition and will require substantial rehabilitation to be deemed safe for any vehicular traffic. The opinion of probable construction costs to upgrade the bridge infrastructure to support a 10-ton emergency hi-rail vehicle is \$2,409,650. While the bridge condition assessment provides a professional opinion of the upgrades and costs required to allow for passage of a 10-ton hi rail vehicle, a detailed inspection and load rating of all the bridges should be completed to confirm its load carrying capacity.

Contents

Amendment.....	i
Executive Summary	ii
1 Project Overview and Objective	1
2 Track Condition Assessment.....	1
2.1 Segment 1: Parksville to McBey Creek (Mile 0.0 – 12.3).....	3
2.1.1 Roadbed.....	3
2.1.2 Track Structure.....	4
2.1.3 Turnouts	5
2.1.4 Segment Summary.....	6
2.2 Segment 2: McBey Creek to Loon Lake (Mile 12.3 - 21.8).....	7
2.2.1 Roadbed.....	7
2.2.2 Track Structure.....	9
2.2.3 Turnouts	9
2.2.4 Segment Summary.....	11
2.3 Segment 3: Loon Lake to Port Alberni (Mile 21.8 - 39.4).....	12
2.3.1 Roadbed.....	12
2.3.2 Track Structure.....	13
2.3.3 Turnouts	15
2.3.4 Segment Summary.....	15
3 Bridge Condition Assessment.....	16
3.1 Inspections	16
3.2 Mile 4.7.....	16
3.2.1 General Observations and Ratings	18
3.2.2 Recommendations and Costs	18
3.3 Mile 12.3.....	19
3.3.1 General Observations and Ratings	20
3.3.2 Recommendations and Costs	21
3.4 Mile 12.4.....	21
3.4.1 General Observations and Ratings	22
3.4.2 Recommendations and Costs	22
3.5 Mile 13.7.....	23
3.5.1 General Observations and Ratings	25
3.5.2 Recommendations and Costs	26
3.6 Mile 13.8.....	27
3.6.1 General Observations and Ratings	28
3.6.2 Recommendations and Costs	29
3.7 Mile 14.0.....	29
3.7.1 General Observations and Ratings	32
3.7.2 Recommendations and Costs	32
3.8 Mile 14.6.....	33
3.8.1 General Observations and Ratings	35
3.8.2 Recommendations and Costs	36
3.9 Mile 17.5.....	37
3.9.1 General Observations and Ratings	39
3.9.2 Recommendations and Costs	39
3.10 Mile 18.1.....	40

3.10.1	General Observations and Ratings	41
3.10.2	Recommendations and Costs	42
3.11	Mile 18.8.....	42
3.11.1	General Observations and Ratings	44
3.11.2	Recommendations and Costs	45
3.12	Mile 20.2.....	45
3.12.1	General Observations and Ratings	47
3.12.2	Recommendations and Costs	47
3.13	Mile 21.4.....	48
3.13.1	General Observations and Ratings	49
3.13.2	Recommendations and Costs	50
3.14	Mile 21.8.....	50
3.14.1	General Observations and Ratings	52
3.14.2	Recommendations and Costs	53
3.15	Mile 22.1.....	53
3.15.1	General Observations and Ratings	55
3.15.2	Recommendations and Costs	55
3.16	Mile 25.0.....	56
3.16.1	General Observations and Ratings	59
3.16.2	Recommendations and Costs	60
3.17	Mile 28.9.....	60
3.17.1	General Observations and Ratings	61
3.17.2	Recommendations and Costs	62
3.18	Mile 29.9.....	62
3.18.1	General Observations and Ratings	64
3.18.2	Recommendations and Costs	65
3.19	Mile 36.5.....	66
3.19.1	General Observations and Ratings	68
3.19.2	Recommendations and Costs	69
3.20	Mile 37.1.....	70
3.20.1	General Observations and Ratings	73
3.20.2	Recommendations and Costs	73
4	References	74

Appendices

Appendix A: Track Condition Summary Table

Appendix B: Bridge Condition Summary Table

Appendix C: Port Alberni Subdivision – Track Chart

Appendix D: Port Alberni Subdivision – Culvert List

1 Project Overview and Objective

HDR was tasked to complete a track and bridge condition assessment along the former E&N Railway Port Alberni Subdivision from Mile 0.00 to 39.4 to support emergency access by a 10-ton vehicle. The goal of this task is to identify the condition of different track, roadbed, bridge, and drainage elements along the corridor.

As part of the Port Alberni Subdivision condition assessment, HDR conducted a field investigation with the support of SVI, ICF, and TFN leveraging each party's experience and knowledge base to understand areas of interest and local construction costs. Key areas of concern are identified, and a recommendation is provided along with its associated cost estimate.

Figure 1-1: Map of Port Alberni Subdivision



2 Track Condition Assessment

A field investigation of the Port Alberni Subdivision was completed by HDR on May 12 to 14, 2025. The inspection was to be completed by hi-rail and foot access where possible. A large number of sections were not accessible by hi-rail or by foot due to track blockage by fallen trees or heavy vegetation growth.

The investigation was broken down into three segments:

- Segment 1: Parksville to McBey Creek (Mile 0.0 to 12.3)
- Segment 2: McBey Creek to Loon Lake (Mile 12.3 to 21.8)
- Segment 3: Loon Lake to Port Alberni (Mile 21.8 to 39.4)

The objective of the track condition assessment was to observe and document any further deterioration of track infrastructure from the last condition inspection completed by WSP in 2019. For the purpose of the inspection, west is considered heading in the direction of increasing mileage to Port Alberni and east is towards Parksville. The field investigation will apply a Good, Fair, Poor rating to each element inspected in Segments 1 – 3 to grade the overall condition of the railway infrastructure to support a 10-ton hi rail vehicle for emergency access. The railway infrastructure has been broken down into three (3) main sections: Roadbed, Track Structure, and Turnouts. Railway elements to be inspected include:

Roadbed:

- Drainage
- Culverts
- ROW and Vegetation

Track Structure:

- Track Horizontal and Vertical Alignment
- Ballast
- Rail
- Ties
- Tie Plates
- Joint Bars
- Spike and Anchors

Turnouts:

- Ballast
- Turnout components
- Ties
- Tie Plates
- Joint Bars
- Spike and Anchors

In locations where the track condition couldn't be observed due to inaccessibility or safety concerns at the time of inspection, previous track condition assessments will be relied upon to grade the infrastructure.

Figure 2-1: Typical Track Cross Section

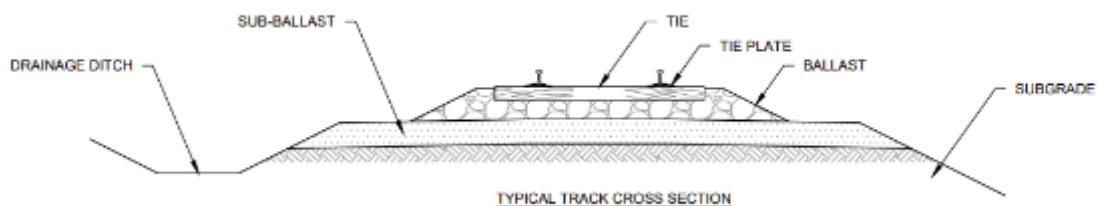

Proposed repairs and recommendations for each track segment are outlined at the end of their respective sections. Each recommended repair includes a description and a corresponding opinion of probable construction estimate. Costs are based on local historical costs and unit price averages provided by SVI personnel. Costs do not include costs of any recommended studies or future maintenance of the rail corridor. Escalation was added to historical costs to make them in line with 2025 costs.

2.1 Segment 1: Parksville to McBey Creek (Mile 0.0 – 12.3)

Due to heavy vegetation, HDR was only able to access the rail corridor near Mile 0.00, Mile 4.70, and Mile 12 – 12.3.

2.1.1 Roadbed

There was one main area of concern where the rail corridor was accessible near Mile 12 where the Little Qualicum River is eroding the river bank about 10ft from the nearest rail.

Drainage

The general drainage condition of the track roadbed could not be assessed as the track was overgrown with heavy vegetation.

Culverts

Culverts within the segment were not inspected as most of the corridor was inaccessible at the time of the inspection.

Vegetation

The segment was found to contain a high amount of vegetation overgrowth and has an overall rating as poor. The vegetation in some areas was too dense to access via hi-rail. One area in particular contained heavy broom growth west of the Highway 4A crossing. Comparing the condition assessment completed in 2019 to current conditions, the vegetation has worsened substantially.

Figure 2-2: Segment 1 - Typical Track Roadbed



Figure 2-3: Eroding River Bank Near Mile 12



2.1.2 Track Structure

Track Horizontal and Vertical Alignment

The overall surface condition for Segment 1: Parksville to McBey Creek was determined to be in fair condition for the areas accessible.

Ballast

The vegetation has overgrown into the ballast and in most areas the ballast could not be observed. The ballast was generally observed to be crushed gravel and heavily fouled with fines where visible. For this segment, the ballast has been rated as poor as the ballast structure could not be observed.

Rail

This segment of track was found to contain 85lb rail in generally fair condition with no major defects noted in the areas that were accessible to inspect. Rail wear was not measured.

Ties

The ties for this segment were identified as 8ft long wood ties. A large percentage of the ties have vegetation coverage and could not be assessed for their condition. Overall, this segment is rated as having poor condition of ties with certain areas to be in fair condition given that the ties contained no defects.

Tie Plate, Joints Bars, Spike and Anchors

Tie plates were noted to be single shouldered along the corridor in this segment. 4-hole joint bars were observed. Joint bars, spikes, anchors and tie plates are in fair condition given the expected vehicle traffic of a 10-ton hi-rail vehicle.

Figure 2-4: Segment 1 - Typical Track Structure



2.1.3 Turnouts

Segment 1 contains two turnouts:

- Mile 0.00 – Parksville Station Switch
- Mile 0.03 – Victoria Sub Switch

Ballast

The ballast is rated as poor as the vegetation has grown within the ballast structure and no features are defined.

Turnout Components

As with the rest of the segment, the turnout components are considered to be in fair condition. Rail wear was not measured.

Ties

The ties for the turnouts assessed were noted to be in fair condition.

Tie Plate, Joints Bars, Spike and Anchors

Tie plates, joint bars, spikes, and anchors are in fair condition given the expected vehicle traffic of a 10-ton hi-rail vehicle.

Overall, the turnout looks to be in fair condition with no major defects found in the visual inspection. This switching component of the turnout was unable to be determined if it could be moved from a normal to diverging route as the switch stands were locked.

Figure 2-5: Segment 1 – Turnout Mile 0.03



2.1.4 Segment Summary

Generally, the main concern for the segment is the heavy vegetation overgrowth and its limitations created for accessing the corridor. Without proper vegetation clearing, it is not possible to assess a large length of the segment. The overall condition of the segment is considered to be fair but further detailed assessments where the corridor was inaccessible are needed.

Recommendations and Costs

The following are a list of recommendations and approximate associated costs:

Table 2-1: Segment 1: Recommendations and Cost

Recommendations	Description	Cost
Vegetation Clearing	The majority of the segment has overgrown vegetation. This segment needs to be cleared to allow for foot and hi-rail access throughout the entire length.	\$50,000
Vegetation Management	In order to safely operate vehicles over the track, management of the vegetation on the segment is required as to not allow the vegetation to overgrow and cause structural, visibility or drainage issues.	\$27,000

Table 2-1: Segment 1: Recommendations and Cost

Recommendations	Description	Cost
River Bank Assessment and Repair	It is recommended to complete a drone flight at Mile 12 to view the river bank erosion which may affect the stability of the track roadbed. Costs included are for estimation of the river bank repair.	\$168,000
Locate and Clean Out Culverts if Required	As mentioned above, most culverts in this segment were not found. Locating and clearing the culverts is recommended to maintain proper drainage conditions.	N/A
Assessing the track condition along between Mile Post 0.0 - 12.0	Once the vegetation has been cleared along the entire segment, it is recommended to hi-rail or walk the track between Mile posts 0.0 - 12.0 to assess the track condition.	N/A
Track Patrols	It is recommended that regular patrols be done on the track segment once the required upgrades are completed for 10-ton hi-rail access. This will ensure the track is in operating condition ahead of any emergency access needs.	N/A
Total (without contingency)		\$245,000

2.2 Segment 2: McBey Creek to Loon Lake (Mile 12.3 - 21.8)

2.2.1 Roadbed

Overall, the roadbed condition for Segment 2: McBey Creek to Loon Lake is in fair condition. There are two locations where the track embankment has started to slide (approx. Mile 14.5 and 16) and will require mitigation.

Various rockslides/rockfall locations were observed at Mile 13.4, 13.73, 13.8, 14.8, 15.6, 15.7, 15.8, 15.85, 15.9, 16.0, 16.1, 16.8, 19.6, as well as a mud slide at Mile 15.2.

Figure 2-6: Segment 2 – Rockslide Mile 13.4



Figure 2-7: Segment 2 – Rockslide Mile 14.8



Drainage

Drainage was given a rating of fair to poor due to the observation that no signs of ponding water are present. There are poor areas where the ballast is severely fouled with fine material and the vegetation could be blocking track and corridor drainage courses.

Culverts

Most culverts along this segment were not found due to the high amount of vegetation.

Vegetation

The segment was found to contain a high amount of vegetation overgrowth and is rated as poor with the exception of a section between approximately Mile 17.0 – 24.8 which is maintained by Rogers Communication. Comparing the condition assessment completed in 2019 to current conditions, the vegetation has worsened substantially.

Figure 2-8: Segment 2 - Typical Track Structure



2.2.2 Track Structure

Track Horizontal and Vertical Alignment

The track horizontal and vertical alignment for Segment 2 was noted to be in fair condition and had no visible signs of major alignment deviations.

Ballast

Ballast was found to be rounded and many cribs between the ties are missing ballast. No clear ballast structure (shoulders and slopes) is present, and vegetation has covered most empty areas where ballast should be. Overall, the condition of ballast is noted as poor.

Rail

The existing rail found in the segment is a mix of 85lb and 100lb rail. There are various sections where the rail has been bent or broken due to rock fall. These locations were noted to be at Mile 15.8, 15.85, 15.9, and 16.6. Aside from these sections, the rail appears to be in fair condition.

Ties

The existing ties for this segment are mostly 8ft long wood ties with some 9ft long ties on curves. Most ties for this segment are covered in vegetation and their conditions were unable to be observed. This segment is given a rating of poor for the ties.

Tie Plate, Joints Bars, Spike and Anchors

The existing track has a mix of 4 and 6-hole joint bars and a mix of single and double sided tie plates. Near Mile 16.8, missing joint bars were noted. For the purpose of operating a 10-ton hi-rail vehicle on this track, the rating is fair for this segment.

2.2.3 Turnouts

Segment 2 contains three turnouts:

- Mile 12.5 - Cameron Lake West Siding Switch
- Mile 21.85 - Aerosmith Siding East Siding Switch
- Mile 21.95 - Aerosmith Siding West Siding Switch

Ballast

The ballast is rated as poor as the vegetation has overgrown within the ballast structure and is heavily fouled with fines.

Turnout Components

The existing turnouts were noted to be 100lb and are considered to be in fair condition.

Ties

The ties for the turnouts assessed were noted to be in fair condition.

Tie Plate, Joints Bars, Spike and Anchors

Overall, the turnouts look to be in fair condition with no defects found in the visual inspection. This switch component of the turnouts were unable to be determined if they could be moved from a normal to diverging route as the switch stands were locked.

Figure 2-9: Segment 2 – Turnout Mile 12.5



Figure 2-10: Segment 2 – Turnout Mile 21.85



Figure 2-11: Segment 2 – Turnout Mile 21.95



2.2.4 Segment Summary

Similar to Segment 1, there is heavy vegetation overgrowth with various tree falls located throughout the segment. Additionally, the segment contains various rockslides/rockfall locations that should be assessed by a professional geologist and debris cleaned up. There are two areas where the embankment is starting to slip towards Cameron Lake. This location should be repaired and assessed for further risk of slippage. Mile 17 – 21.8 is maintained by Rogers Communication as part of their buried fibre optic cable that is within the corridor. The overall condition of the segment is considered to be fair but further detailed assessments for areas of concern are needed.

Recommendations and Costs

The following are a list of recommendations and approximate associated costs:

Table 2-2: Segment 2: Recommendations and Cost

Recommendations	Description	Cost
Brush Clearing	Most of the segment has overgrown plants and trees, and multiple fallen trees with the exception from Mile 17.0 – 21.8 which is maintained by Rogers Communications. This segment needs to be cleared to allow for foot and hi-rail access throughout the entire length.	\$19,000
Vegetation Management	To safely operate vehicles over the track, management of the vegetation on the segment is required as to not allow vegetation overgrowth and cause structural, visibility or drainage issues.	\$27,000
Rock Fall and Mud Slide Clean Up	There are +10 rockslides that were found at the time of investigation. The debris will need to be cleaned up to allow for vehicle access and further assessments.	\$37,000
Rock Fall Assessment	A rock fall assessment by a qualified geotechnical engineer is required for the areas in which rock fall was found to determine if this issue requires mediation or not.	N/A
Broken / Bent Rail Replacement	Four locations were noted to have bent or broken rail. Replacing these sections of rail is required to operate vehicles through the segment.	\$6,000

Table 2-2: Segment 2: Recommendations and Cost

Recommendations	Description	Cost
Embankment Assessment and Stabilization	Two locations (Mile post 14.5 and 16) have small stretches of embankment slides. An assessment of the cause of embankment slide is recommended to provide a remediation for this issue. Costs to rebuild the shoulder of the embankment slide is provided.	\$24,000
Locate and Clean Out Culverts if Required	As mentioned above, most culverts in this segment were not found. Locating and clearing the culverts is recommended to maintain proper drainage conditions.	N/A
Track Patrols	It is recommended that regular patrols be done on the track segment once the required upgrades are completed for 10-ton hi-rail access. This will ensure the track is in operating condition ahead of any emergency access needs.	N/A
Total (without contingency)		\$113,000

2.3 Segment 3: Loon Lake to Port Alberni (Mile 21.8 - 39.4)

Due to heavy vegetation, tree fall and rock fall, HDR was only able to access between Mile 34 - 36.28 and Mile 36.28 and 39.4.

2.3.1 Roadbed

Overall, the roadbed condition for Segment 3: Loon Lake to Port Alberni is in fair to poor condition. The segment is covered by vegetation and various tree fall and rockslide locations, as well as a track embankment washout noted around Mile 24.4. Closer to the end of the subdivision within the town limits the condition is fair but most of the segment is in poor condition. Further assessment and mitigation will be required for the rockslides and washout.

Drainage

Drainage was rated as fair due to the observation that no signs of ponding water are present.

Culverts

It was noted that one of the culverts had been damaged at Mile 31.5 and had slight undermining at the outlet. Culverts were unable to be located in areas where the corridor was accessible due to heavy vegetation growth.

Vegetation

The segment was found to contain a high amount of vegetation overgrowth and is scored as poor. Comparing the condition assessment completed in 2019 to current conditions, the vegetation has worsened substantially.

Figure 2-12: Segment 3 - Typical Track Roadbed



Figure 2-13: Segment 3 – Track Embankment Washout Mile 24.4



2.3.2 Track Structure

Track Horizontal and Vertical Alignment

The track horizontal and vertical alignment for Segment 3 was noted to be in fair condition for the areas accessible. Further assessment to evaluate the track alignment will be required in inaccessible areas.

Ballast

Ballast was found to be rounded and large stretches of track missing ballast on the shoulder exposing the end of tie. As in the other segments, there is no clear ballast structure (shoulders and slopes) for most areas and vegetation has covered the limits of the ties. Overall, the condition of ballast is noted as poor.

Rail

The existing rail found in the segment was found to be 85lb and is noted to be in fair condition.

Ties

On average the ties vary between being in a fair and poor condition. A large number of ties are seen to have defects and are covered in vegetation.

Tie Plate, Joints Bars, Spike and Anchors

The existing track was noted to have 4-hole joint bars and single shoulder tie plates. The rating is fair for tie plates, joint bars, spikes, and anchors in this segment.

Figure 2-14: Segment 3 - Typical Rail/Tie/Ballast Structure

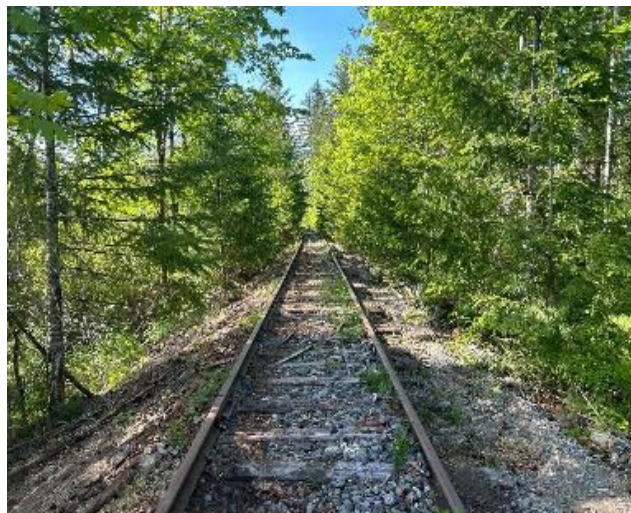

Figure 2-15: Segment 3 – Tree Fall Mile 31.7



2.3.3 Turnouts

No turnouts were found for this segment.

2.3.4 Segment Summary

Similar to the other two segments, the corridor is covered in heavy vegetation overgrowth with various tree falls and rockslides. Much of the segment was not accessible by foot or hi-rail due to these blockages. The overall condition of the segment is considered to be fair but further detailed assessments for areas of concern are needed.

Recommendations and Costs

The following are a list of recommendations and approximate associated costs:

Table 2-3: Segment 3: Recommendations and Cost

Recommendations	Description	Cost
Brush Clearing	Most of the segment has overgrown plants and trees, and multiple fallen trees. This needs to be cleared to allow for foot and hi-rail access throughout the entire length. There is a 2 mile stretch within the Port Alberni near end of track that does not require brush clearing.	\$62,000
Vegetation Management	To safely operate vehicles over the track, management of the vegetation on the segment should be completed after brush clearing to limit future overgrowth and cause structural, visibility or drainage issues.	\$27,000
Rock Fall Clean Up	There are 3 rock / tree slides that were found at the time of the investigation. The debris will need to be cleaned up to allow for vehicle access and further assessments.	\$6,000
Rock Fall Assessment	A rock fall assessment by a qualified geotechnical engineer is required for the areas in which rock fall was found to determine if this issue requires mediation or not.	N/A
Washout Out Repair	The washout of the culvert at Mile 24.4 will require repair prior to passage of hi-rail vehicles.	\$100,000
Locate and Clean Out Culverts if Required	As mentioned above, most culverts in this segment were not found. Locating and clearing the culverts is recommended to maintain proper drainage conditions.	N/A
Culvert Undermining Monitoring	A 70" CSP culvert was seen to have the outlet undermining. The area is recommended to be monitored for further deterioration.	N/A
Track Patrols	It is recommended that regular patrols be done on the track segment once the required upgrades are completed for 10-ton hi-rail access. This will ensure the track is in operating condition ahead of any emergency access needs	N/A
Total (without contingency)		\$195,000

3 Bridge Condition Assessment

3.1 Inspections

HDR completed a field visit to the Port Alberni Subdivision to perform a bridge condition assessment on all 19 of the existing bridges along the rail corridor. The assessments were completed between May 12th and 13th, 2025 along side SVI, TFN, ICF, and NovaForest Services Ltd. TFN and NovaForest Services Ltd. provided selected drone footage to support the assessment of areas of the bridges which were not easily or safely accessible. HDR was accompanied by SVI on the bridge condition assessment on May 14th. Due to heavy vegetation overgrowth and fallen trees, hi-rail access was not possible for most of the corridor, and bridges were accessed on foot from the nearest access road.

In 2021, WSP conducted a load evaluation inspection and prepared a report for 4 of the 19 bridges to assess their capability to support temporary crossings for construction equipment, in support of the Roger's fibre installation along Mile 17.0 – Mile 24.8. Prior to that, an inspection of 13 of the 19 bridges was completed by WSP in August 2019 to document the general condition of the structures as part of the Island Corridor Condition. No previous inspections prior to 2019 were noted to assess the structures for rehabilitation and maintenance.

The objective of the bridge condition assessment was to visually assess the bridges for signs of - advanced deterioration and deficiencies and to compare findings – with WSP's August 2019 bridge condition inspection. For the purpose of the inspection, west is considered heading in the direction of increasing mileage toward Port Alberni and east is towards Parksville. Hammer sounding was performed to a few select members to test for signs of decay. Bridge members were visually inspected in accessible areas to note the conditions and elements that were of concern. Ratings were applied based on a Good, Fair, or Poor observation of the inspected members to grade the overall condition of the railway infrastructure to support a 10-ton vehicle for emergency access. The bridge infrastructure has been broken down into four (4) main sections: Approaches, Bridge Deck, Superstructure, and Substructure. Structural timber, steel, and concrete elements nomenclature follows the American Railway Engineering and Maintenance of Way Association (AREMA) bridge inspection handbook.

Proposed repairs and recommendations for each bridge are outlined at the end of their respective sections. Each recommended repair includes a description and a corresponding opinion of probable construction cost estimate. Costs were based on local historical costs and unit price averages provided by SVI personnel. Escalation was added to historical costs to align them with 2025 costs. Costs do not include any recommended studies or future maintenance, or inspections of the rail corridor.

3.2 Mile 4.7

The Mile 4.7 bridge is a 75ft long open deck single span deck plate girder bridge crossing over French Creek.

Table 3-1: Bridge - Mile 4.7

Original Construction Date	1910
Inspection Date	May 14, 2025
Previous Inspection Date	August 15, 2019
Total Length	75' (22.9m)
Bridge Design Load	E-50 (Per SVI Inventory, not confirmed)
Feature Crossed	French Creek
Superstructure	Deck Plate Girder
Substructure	Concrete Abutments
Track Alignment	Tangent
Rail Weight	100lb
Track Gradient	0%

Figure 3-1: Bridge General Arrangement Drawing - Mile 4.7

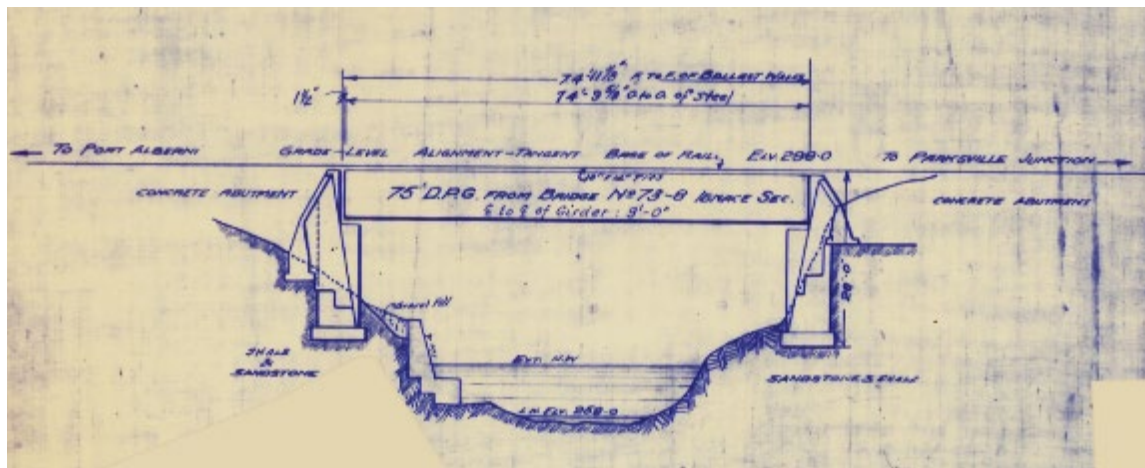

Figure 3-2: Bridge at Mile 4.7 – Deck View



3.2.1 General Observations and Ratings

Approaches/Track Surface

- Approaches on either side of the bridge have vegetation growth on the roadbed but are in fair condition.

Bridge Deck

- Deck ties and guard timbers are in fair condition, with only minor aging of the components. The running and Jordan rails are in fair condition.

Superstructure

- The paint is peeling, causing surface rust on all steel surfaces. The top and bottom girder flanges have debris buildup throughout their length, and pitting up to 3/16" was noted on horizontal surfaces throughout. Overall, the superstructure is in fair condition.

Substructure

- Abutments, wingwalls, and stems are covered in moss but based on the overall condition of the elements, appear to be in fair condition..

3.2.2 Recommendations and Costs

Overall, the condition of the bridge is considered to be fair, and no further deterioration or deficiencies were noted compared to the previous 2019 inspection.

The following is a list of recommendations and approximate associated costs.

Table 3-2: Bridge Mile 4.7: Recommendations and Cost

Recommendations	Description	Cost
Brush Clearing Around Bridges	General vegetation clearing around the bridge is recommended where feasible to reduce the risk of timber decay and reduce the fire hazard	\$5,000
Visual Bridge Inspection	It is recommended that annual inspections be conducted on the bridge once the required upgrades are completed for 10-ton hi-rail access. This will ensure the bridge remains in operating condition ahead of any emergency access needs.	N/A
Total (without contingency)		\$5,000

3.3 Mile 12.3

The Mile 12.3 bridge is a ballasted deck 29ft long single span composite steel plate girder bridge crossing over McBey Creek. A drone flight was not conducted because the different areas of the bridge were accessible by foot.

Table 3-3: Bridge - Mile 12.3

Original Construction Date	1976
Inspection Date	May 14, 2025
Previous Inspection Date	August 15, 2019
Total Length	29' (8.8m)
Bridge Design Load	E-75 (CP Form 925)
Feature Crossed	McBey Creek
Superstructure	Composite Steel Plate Girders
Substructure	Concrete Abutments
Track Alignment	9°-00' Curve (3" Super Elevation in Bridge Seat)
Rail Weight	100lb
Track Gradient	0.9%

Figure 3-3: Bridge General Arrangement Drawing - Mile 12.3

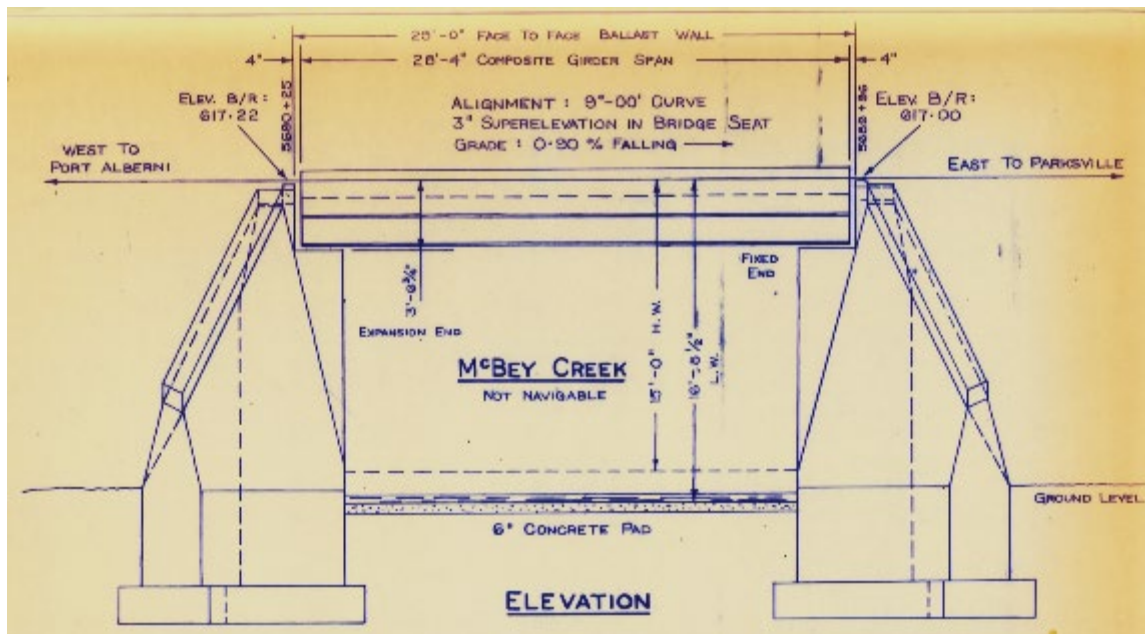

Figure 3-4: Bridge at Mile 12.3 – South Elevation



Figure 3-5: Bridge at Mile 12.3 – Deck View Looking West



3.3.1 General Observations and Ratings

Approaches/Track Surface

- Approaches on either side of the bridge are in fair condition.

Bridge Deck

- Ballast on deck has minimal vegetation growth and is lightly worn.
- The running and Jordan rails are in fair condition.
- Deck structure and curbs are in relatively good condition.
- Overall, the bridge deck is in fair condition.

Superstructure

- Aside from some moss buildup and aging, the steel composite beams are in fair condition.

Substructure

- Bearings were not visible.
- The foundations appear to be on rock.
- Bridge seats and wingwalls are covered in moss.
- The overall condition of the elements is fair.

3.3.2 Recommendations and Costs

Overall, the condition of the bridge is considered to be fair, and no further deterioration or deficiencies were noted compared to the previous 2019 inspection.

The following is a list of recommendations and approximate associated costs.

Table 3-4: Bridge Mile 12.3: Recommendations and Cost

Recommendations	Description	Cost
Visual Bridge Inspection	It is recommended that annual inspections be conducted on the bridge once the required upgrades are completed for 10-ton hi-rail access. This will ensure the bridge remains in operating condition ahead of any emergency access needs.	N/A
Total (without contingency)		-

3.4 Mile 12.4

The Mile 12.4 bridge is a 75.5ft long open deck single span deck plate girder bridge crossing over Little Qualicum River. A drone flight was not conducted because the different areas of the bridge were accessible by foot.

Table 3-5: Bridge - Mile 12.4

Original Construction Date	1909
Inspection Date	May 12, 2025
Previous Inspection Date	August 15, 2019
Total Length	75.5' (23.0m)
Bridge Design Load	E-50 (CP Form 925)
Feature Crossed	Little Qualicum River
Superstructure	Deck Plate Girders
Substructure	Concrete Abutments
Track Alignment	9°-00' Curve
Rail Weight	85lb
Track Gradient	1.23%

Figure 3-6: Bridge General Arrangement Drawing - Mile 12.4

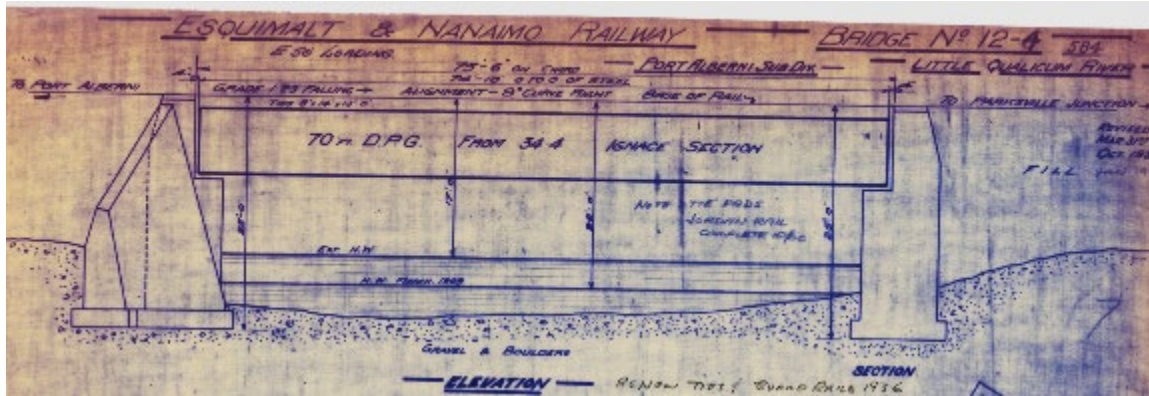

3.4.1 General Observations and Ratings

Approaches/Track Surface

- Approaches on either side of the bridge are in fair condition.

Bridge Deck

- Overall, the bridge deck is in fair condition.

Superstructure

- The paint has failed, and there is minor corrosion throughout the steel members.
- Overall, the steel girders are in fair condition.

Substructure

- The overall condition of the substructure is fair.

3.4.2 Recommendations and Costs

Overall, the condition of the bridge is considered to be fair, and no further deterioration or deficiencies were noted compared to the previous 2019 inspection.

The following is a list of recommendations and approximate associated costs.

Table 3-6: Bridge Mile 12.4: Recommendations and Cost

Recommendations	Description	Cost
Visual Bridge Inspection	It is recommended that annual inspections be conducted on the bridge once the required upgrades are completed for 10-ton hi-rail access. This will ensure the bridge remains in operating condition ahead of any emergency access needs.	N/A
Total (without contingency)		-

3.5 Mile 13.7

The Mile 13.7 bridge is a 209.5ft long open deck timber frame trestle bridge that crosses over a steep slope in close proximity to Cameron Lake.

This is one of the four bridges that had a load rating completed in 2022. In that study, it was determined that without repair/rehabilitation, the bridge did not have the capacity to carry permitted controlled loads proposed at that time. Repair/rehabilitation was not observed at the time of inspection. The underside of the bridge was not accessible due to the steep slopes. A drone flight was completed at the bridge.

Table 3-7: Bridge – Mile 13.7

Original Construction Date	1911. Most recently rebuilt in 1971
Inspection Date	May 12, 2025
Previous Inspection Date	December 9, 2021
Total Length	209.5' (63.9m)
Bridge Design Load	E-60 (CP Form 925)
Feature Crossed	Dry
Superstructure	Timber Frame Trestle
Substructure	Square Timber Column Bents
Track Alignment	9°-30' to 4°-15' Reverse Curve
Rail Weight	100lb
Track Gradient	1.42%

Figure 3-7: Bridge General Arrangement Drawing – Mile 13.7

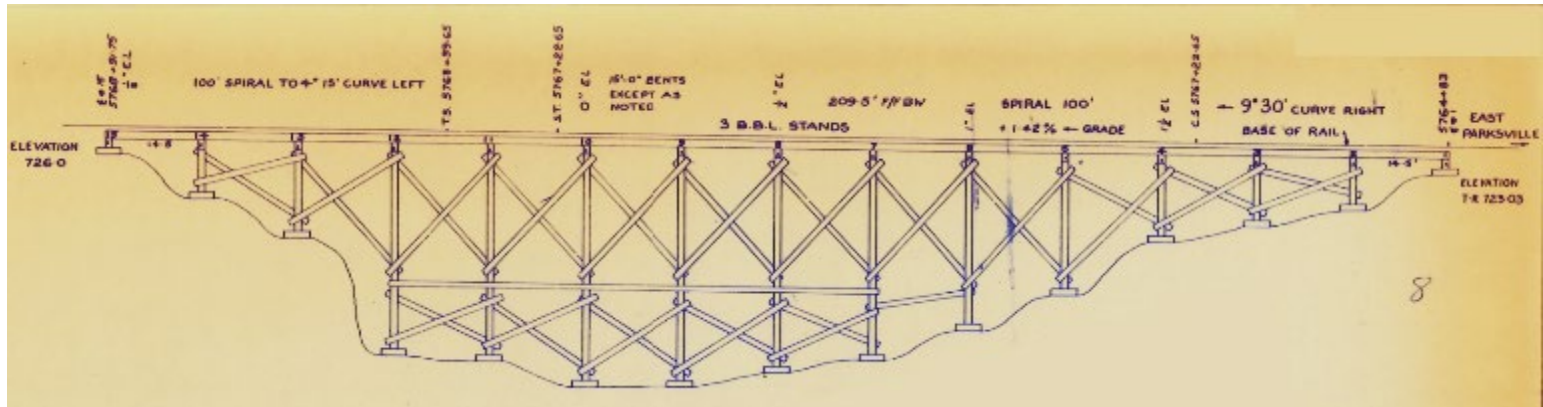

Figure 3-8: Bridge at Mile 13.7 – Deck View Looking West



Figure 3-9: Bridge at Mile 13.7 – Aerial View



Figure 3-10: Bridge at Mile 13.7 – North Elevation Looking East



3.5.1 General Observations and Ratings

Approaches/Track Surface

- Approaches on either side of the bridge are in fair condition.

Bridge Deck

- There is a refuge bay that has decayed, separated from the bridge deck, and fallen to the ground.

- The deck ties are untreated, and a majority are severely decayed and in very poor condition. Various deck ties are missing throughout.
- Guard timbers have minor decay and are in poor condition.
- Overall, the bridge deck is in poor condition.

Superstructure

- Stringers are in fair condition.
- Stringers were observed to have shims under them to provide the curve superelevation.
- Overall, the superstructure is in fair to poor condition.

Substructure

- Bent caps have light to medium decay.
- The posts are fair throughout.
- There are many broken and split longitudinal-braces.
- Sway bracing is showing signs of decay.
- Bent 12 has concrete pedestals supporting posts, which are in fair condition.
- The overall condition of the substructure is fair to poor.

3.5.2 Recommendations and Costs

Overall, the condition of the bridge is considered to be poor and there is further deterioration of the items noted in the previous 2019 and 2021 inspections. The previous reports had also identified undermining for the mud sills in some locations.

The following is a list of recommendations and approximate associated costs:

Table 3-8: Bridge Mile 13.7: Recommendations and Cost

Recommendations	Description	Cost
Replace All Deck Ties	Deck ties are in poor condition or missing. Replacement of all ties is recommended for the operation of any vehicle over this bridge.	\$136,500
Replace Guard Timber	Guard timbers are decaying, and replacement is recommended.	Included in tie replacement cost
Brush Clearing Around Bridges	General vegetation clearing around the bridge is recommended where feasible to reduce the risk of timber decay and fire hazard.	\$10,000
Visual Bridge Inspection	It is recommended that annual inspections be conducted on the bridge once the required upgrades are completed for 10-ton hi-rail access. This will ensure the bridge remains in operating condition ahead of any emergency access needs.	N/A
Total (without contingency)		\$146,500

3.6 Mile 13.8

The Mile 13.8 bridge is a 105ft long open deck timber frame trestle bridge crossing over a steep slope in close proximity to Cameron Lake.

This is one of the four bridges that had a load rating completed in 2022. In that study, it was determined that without repair/rehabilitation, the bridge did not have the capacity to carry permitted controlled loads proposed at that time. Repair/rehabilitation was not observed at the time of inspection. The underside of the bridge was not accessible due to the steep slopes. A drone flight was conducted at the bridge.

Table 3-9: Bridge - Mile 13.8

Original Construction Date	1911. Most recently replaced in 1970
Inspection Date	May 12, 2025
Previous Inspection Date	December 9, 2021
Total Length	105' (32.0m)
Bridge Design Load	E-60 (CP Form 925)
Feature Crossed	Dry
Superstructure	Timber Frame Trestle
Substructure	Square Timber Column Bents
Track Alignment	4°-15' Curve
Rail Weight	100lb
Track Gradient	1.35%

Figure 3-11: Bridge General Arrangement Drawing - Mile 13.8

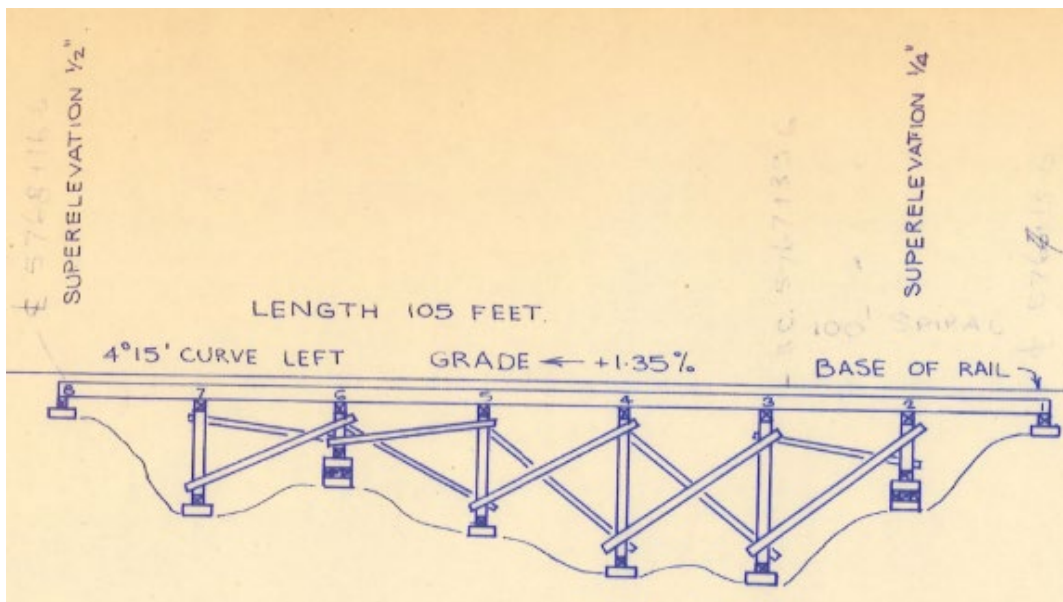

Figure 3-12: Bridge at Mile 13.8 – Deck View Looking West



Figure 3-13: Bridge at Mile 13.8 – Typical Bent Cap View Looking West



3.6.1 General Observations and Ratings

Approaches/Track Surface

- Approaches on either side are overgrown with vegetation but otherwise in fair condition.

Bridge Deck

- The deck ties are untreated, severely decayed, and in very poor condition.
- The running and Jordan rails are in fair condition.
- Guard timber has minor decay and is in fair condition.
- Overall, the bridge deck is in poor condition.

Superstructure

- Stringers are in fair condition.
- Overall, the superstructure is in fair condition.

Substructure

- Bent caps are in fair condition.
- The posts are fair throughout.
- Bracing is showing signs of minor decay.
- Mud sills were unobservable due to vegetation overgrowth.
- The overall condition of the substructure is fair.

3.6.2 Recommendations and Costs

Overall, the condition of the bridge is considered to be fair to poor, with elements showing no further deterioration compared to the previous 2019 and 2021 inspections. Advanced vegetation overgrowth is the most significant change between the previous inspections.

The following is a list of recommendations and approximate associated costs.

Table 3-10: Bridge Mile 13.8: Recommendations and Cost

Recommendations	Description	Cost
Replace All Deck Ties and Guard Timber	Deck ties are in poor condition. Replacement of all ties is recommended prior to the operation of any vehicle over this bridge.	\$68,250
Brush Clearing Around Bridges	General vegetation clearing around the bridge is recommended where feasible to reduce the risk of timber decay and fire hazard.	\$5,000
Visual Bridge Inspection	It is recommended that annual inspections be conducted on the bridge once the required upgrades are completed for 10-ton hi-rail access. This will ensure the bridge remains in operating condition ahead of any emergency access needs.	N/A
Total (without contingency)		\$73,250

3.7 Mile 14.0

At Mile 14.0 is a 225ft long open deck timber frame trestle bridge crossing over a steep slope in close proximity to Cameron Lake.

This is one of the four bridges that had a load rating completed in 2022. In that study, it was determined that without repair/rehabilitation, the bridge did not have the capacity to carry permitted controlled loads proposed at that time. Repair/rehabilitation was not observed at the time of inspection. The underside of the bridge was not accessible due to the steep slopes. A drone flight was not completed at the bridge due to the vegetation overgrowth adjacent to the bridge.

Table 3-11: Bridge - Mile 14.0

Original Construction Date	1971
Inspection Date	May 12, 2025
Previous Inspection Date	December 9, 2021
Total Length	225' (68.6m)
Bridge Design Load	E-60 (CP Form 925)
Feature Crossed	Dry
Superstructure	Timber Frame Trestle
Substructure	Concrete Abutment and Square Timber Column Bents with Concrete Foundations
Track Alignment	Tangent
Rail Weight	85lb
Track Gradient	1.55%

Figure 3-14: Bridge General Arrangement Drawing - Mile 14.0

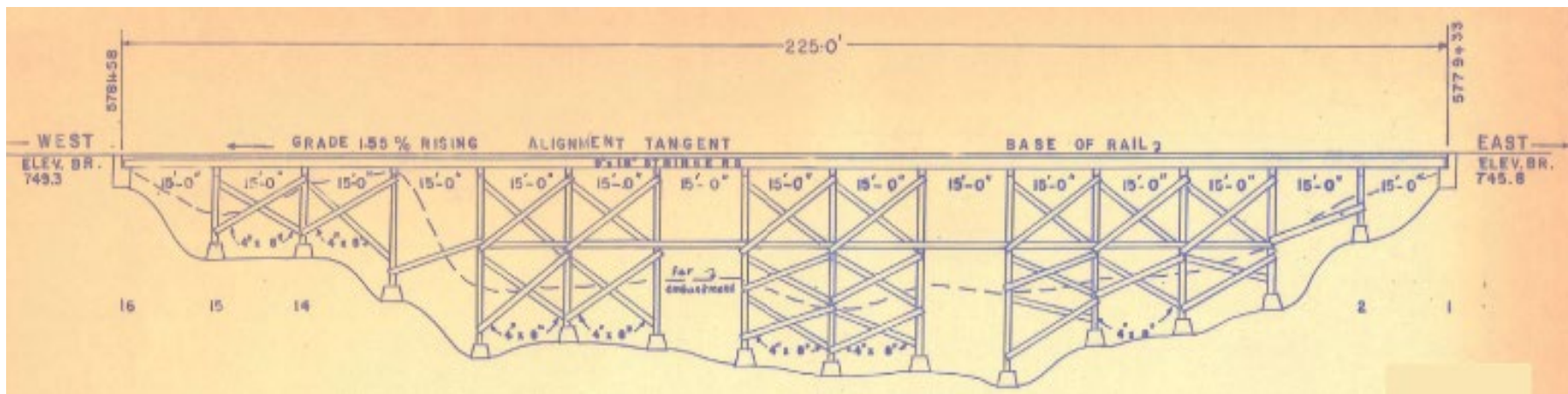

Figure 3-15: Bridge at Mile 14.0 – Deck View Looking West



Figure 3-16: Bridge at Mile 14.0 – Typical Bent Frame



3.7.1 General Observations and Ratings

Approaches/Track Surface

- Approaches on either side of the bridge are in fair condition.

Bridge Deck

- The deck ties are in fair condition.
- Guard timbers are in fair condition.
- Overall, the bridge deck is in fair condition.

Superstructure

- Stringers are in fair condition with minor decay in some areas.
- Overall, the superstructure is in fair condition.

Substructure

- Concrete abutments have moss growth.
- Concrete pedestal footings are in fair condition.
- The bracing throughout is in fair condition.
- The overall condition of the substructure is fair.

3.7.2 Recommendations and Costs

Overall, the condition of the bridge is considered to be fair, and there is no further deterioration of the items noted in the previous 2019 and 2021 inspections.

The following is a list of recommendations and approximate associated costs.

Table 3-12: Bridge Mile 14.0: Recommendations and Cost

Recommendations	Description	Cost
Brush Clearing Around Bridges	General vegetation clearing around the bridge is recommended where feasible to reduce the risk of timber decay and fire hazard.	\$10,000
Visual Bridge Inspection	It is recommended that annual inspections be conducted on the bridge once the required upgrades are completed for 10-ton hi-rail access. This will ensure the bridge remains in operating condition ahead of any emergency access needs.	N/A
Total (without contingency)		\$10,000

3.8 Mile 14.6

At Mile 14.6 is a 441ft long open deck timber frame trestle bridge crossing over a steep slope in close proximity to Cameron Lake.

This is one of the four bridges that had a load rating completed in 2022. In that study, it was determined that without repair/rehabilitation, the bridge did not have the capacity to carry permitted controlled loads proposed at that time. Repair/rehabilitation was not observed at the time of inspection. The underside of the bridge was not accessible due to the steep slopes. A drone flight was conducted at the bridge.

Table 3-13: Bridge – Mile 14.6

Original Construction Date	1953
Inspection Date	May 12, 2025
Previous Inspection Date	December 9, 2021
Total Length	441' (134.4m)
Bridge Design Load	E-50 (CP Form 925)
Feature Crossed	Dry
Superstructure	Timber Frame Trestle
Substructure	Concrete Abutment and Square Timber Column Bents with Concrete Foundations
Track Alignment	10°-00' Curve to Tangent
Rail Weight	100lb
Track Gradient	1.40%

Figure 3-17: Bridge General Arrangement Drawing – Mile 14.6

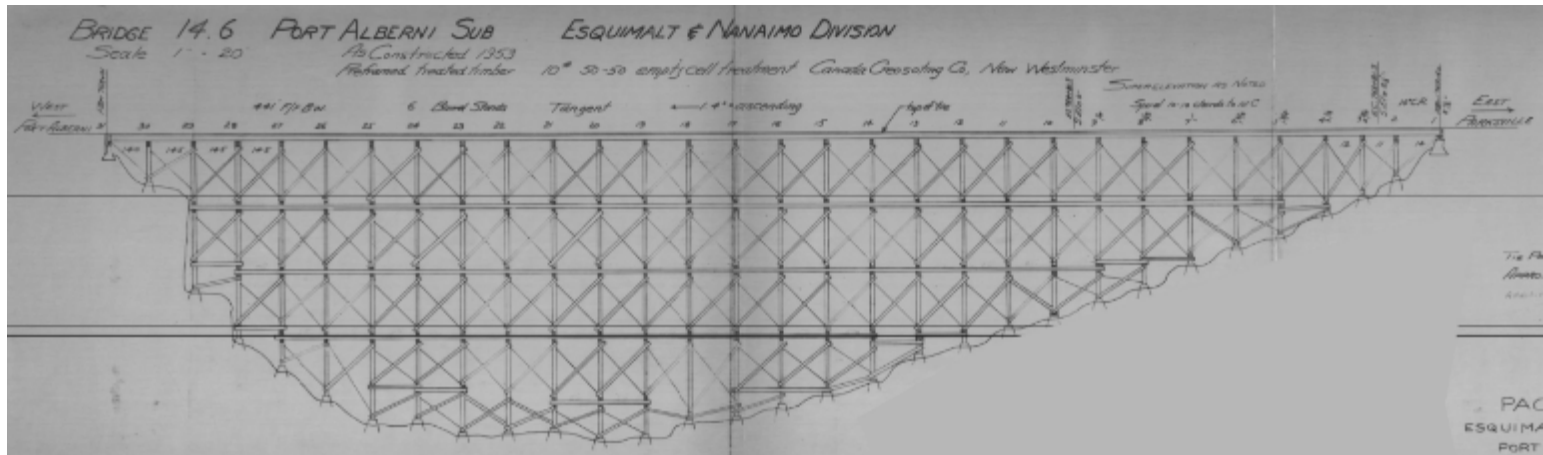

Figure 3-18: Bridge at Mile 14.6 – Deck View Looking East



Figure 3-19: Bridge at Mile 14.6 – South Elevation Looking East



Figure 3-20: Bridge at Mile 14.6 – Stringer Chord Splitting



3.8.1 General Observations and Ratings

Approaches/Track Surface

- Approaches on either side of the bridge are in fair condition.

Bridge Deck

- The entire deck is untreated and in poor condition, with full replacement required. There are missing deck ties and the remaining ones are in very poor condition.

- Running and Jordan rails are in fair condition.
- Guard timbers and refuge bays are in poor condition.
- Overall, the bridge deck is in poor condition.

Superstructure

- Stringers 1 and 8 are untreated and were added to the bridge to increase its load capacity. Stringers 1 and 8 are showing signs of decay and splitting.
- Stringer 8 in span 3 is observed to be split.
- Overall, the superstructure is in fair to poor condition.

Substructure

- Bent caps are in fair condition.
- Bent 15, post 2, was observed to be splitting vertically.
- Undermining of Bent 2 concrete pedestals was noted.
- Cross bracing is splitting, cracked, or missing in various locations.
- Concrete abutments are in fair condition with only minor aging.
- The overall condition of the substructure is fair.

3.8.2 Recommendations and Costs

Overall, the condition of the bridge is considered to be fair, with minor deterioration in addition to what was mentioned in the previous 2019 and 2021 inspections.

The following is a list of recommendations and approximate associated costs:

Table 3-14: Bridge Mile 14.6: Recommendations and Cost

Recommendations	Description	Cost
Replace All Deck Ties	Deck ties are in poor condition or missing. Replacement of all ties is recommended for the operation of any vehicle over this bridge.	\$286,650
Replace Guard timber	Guard timbers are decaying, and replacement is recommended.	Included in the tie replacement cost.
Brush Clearing Around Bridges	General vegetation clearing around the bridge is recommended where feasible to reduce the risk of timber decay and fire hazard.	\$20,000
Visual Bridge Inspection	It is recommended that annual inspections be conducted on the bridge once the required upgrades are completed for 10-ton hi-rail access. This will ensure the bridge remains in operating condition ahead of any emergency access needs.	N/A
Total (without contingency)		\$306,650

3.9 Mile 17.5

The Mile 17.5 bridge is a 195ft long open deck timber frame trestle bridge crossing over Mountain Creek. This bridge has not previously been inspected. The underside of the bridge was not accessible due to the steep slopes. A drone flight was conducted at the bridge.

Table 3-15: Bridge – Mile 17.5

Original Construction Date	1911. Most recently replaced in 1956
Inspection Date	May 12, 2025
Previous Inspection Date	N/A
Total Length	195' (59.4m)
Bridge Design Load	E-60 (CP Form 925)
Feature Crossed	Mountain Creek
Superstructure	Timber Frame Trestle
Substructure	Concrete Abutment and Square Timber Column Bents with Concrete Foundations
Track Alignment	12°-00' Curve
Rail Weight	85lb
Track Gradient	1.50%

Figure 3-21: Bridge General Arrangement Drawing – Mile 17.5

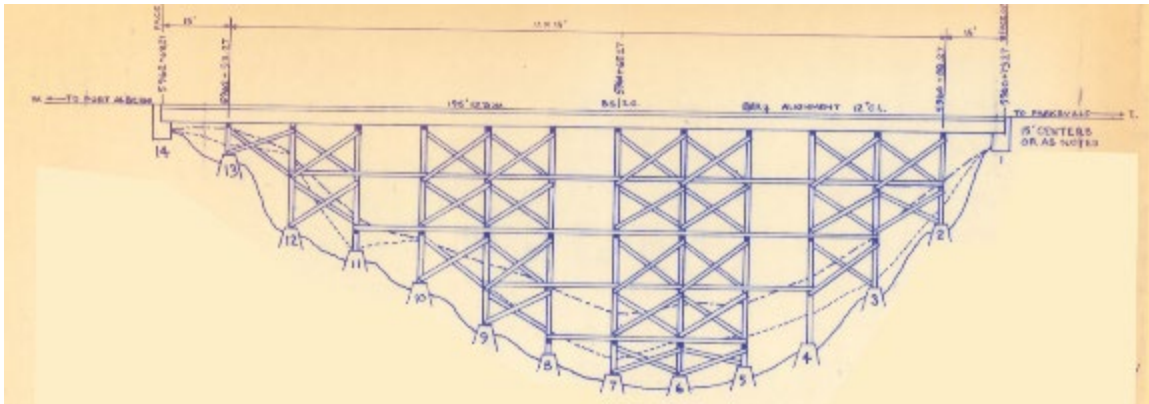

Figure 3-22: Bridge at Mile 17.5 – Deck View Looking West



Figure 3-23: Bridge at Mile 17.5 – Abutment View Looking East



Figure 3-24: Bridge at Mile 17.5 – Center Interior Bents and Creek View



3.9.1 General Observations and Ratings

Approaches/Track Surface

- Approaches on either side of the bridge are in fair condition.

Bridge Deck

- There is a single damaged tie near the east end of the bridge along with a 20ft stretch of damaged guard timber.
- Running and Jordan rails are in fair condition.
- Fall arrest cable installed between Jordan rails.
- Overall, the bridge deck is in fair condition.

Superstructure

- Stringers were noted to be in fair condition.
- Overall, the superstructure is in fair condition.

Substructure

- Bent caps were noted to be in fair condition.
- On bent 2, post 4, there is a minor vertical split.
- There is slight moss growth on the concrete abutments.
- No noticeable splitting, cracking, or missing bracing.
- Concrete pedestal footings are covered in high vegetation overgrowth.
- The overall condition of the substructure is fair.

3.9.2 Recommendations and Costs

Overall, the condition of the bridge is considered to be fair with only a few items identified for replacement.

The following is a list of recommendations and approximate associated costs:

Table 3-16: Bridge Mile 17.5: Recommendations and Cost

Recommendations	Description	Cost
Replacement of 1 Deck Tie	There is one bridge tie that has been damaged and needs to be replaced.	\$650
Replace Section of Guard Rail	There is one 20ft stretch of guard rail that is damaged and to be replaced.	Included in tie replacement cost.
Brush Clearing Around Bridges	General vegetation clearing around the bridge is recommended where feasible to reduce the risk of timber decay and fire hazard.	\$10,000
Visual Bridge Inspection	It is recommended that annual inspections be conducted on the bridge once the required upgrades are completed for 10-ton hi-rail access. This will ensure the bridge remains in operating condition ahead of any emergency access needs.	N/A
Total (without contingency)		\$10,650

3.10 Mile 18.1

The Mile 18.1 bridge is a 165ft long open deck timber frame trestle bridge crossing over an unnamed waterway. This bridge has not previously been inspected. The underside of the bridge was not accessible due to the steep slopes. The drone was not flown due to the heavy vegetation overgrowth at the time of inspection.

Table 3-17: Bridge - Mile 18.1

Original Construction Date	1911. Most recently replaced in 1956
Inspection Date	May 12, 2025
Previous Inspection Date	N/A
Total Length	165' (50.3m)
Bridge Design Load	E-50
Feature Crossed	Unnamed Waterway
Superstructure	Timber Frame Trestle
Substructure	Square Timber Column Bents
Track Alignment	Tangent to 7°-00' Curve
Rail Weight	85lb
Track Gradient	1.41%

Figure 3-25: Bridge General Arrangement Drawing - Mile 18.1

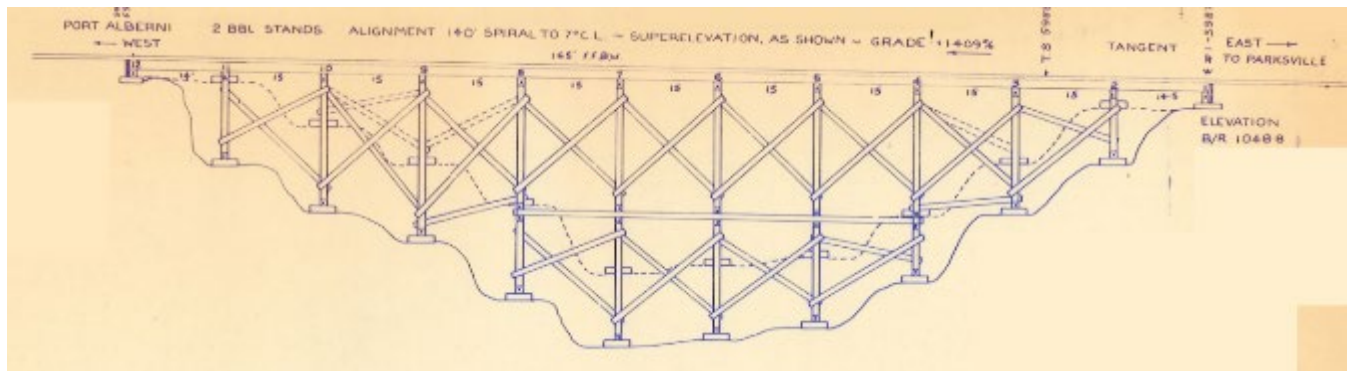

Figure 3-26: Bridge at Mile 18.1 – Deck View Looking West



Figure 3-27: Bridge at Mile 18.1 – Under Side View Looking East



3.10.1 General Observations and Ratings

Approaches/Track Surface

- Approaches on either side of the bridge are in fair condition.

Bridge Deck

- Deck ties and guard timbers are heavily decayed with many deck ties missing.
- Overall, the bridge deck is in poor condition.

Superstructure

- Stringers and pier caps were noted to be in fair condition.
- Overall, the superstructure is in fair condition.

Substructure

- Sway bracing, caps, and posts at lower tiers have vegetation growing out of them.
- There is some surface deterioration of timber members due to vegetation and water on north side of bridge.
- The overall condition of the substructure is fair.

3.10.2 Recommendations and Costs

Overall, the condition of the bridge is considered to be fair with only a few items identified for replacement.

The following is a list of recommendations and approximate associated costs.

Table 3-18: Bridge Mile 18.1: Recommendations and Cost

Recommendations	Description	Cost
Replace All Deck Ties	Deck ties are in poor condition or missing. Replacement of all ties is recommended for the operation of any vehicle over this bridge.	\$107,250
Replace Guard timber	Guard timbers are decaying, and replacement is recommended.	Included in tie replacement cost.
Brush Clearing Around Bridges	General vegetation clearing around the bridge is recommended where feasible to reduce the risk of timber decay and fire hazard	\$10,000
Visual Bridge Inspection	It is recommended that annual inspections be conducted on the bridge once the required upgrades are completed for 10-ton hi-rail access. This will ensure the bridge remains in operating condition ahead of any emergency access needs.	N/A
Total (without contingency)		\$117,250

3.11 Mile 18.8

The Mile 18.8 bridge is a 197ft long bridge that is a mix of open deck timber frame trestles on either side of the through plate girder center span crossing over a steep slope. This bridge has not previously been inspected. The underside of the bridge was not accessible due to the steep slopes. The drone was flown at this bridge during the time of inspection.

Table 3-19: Bridge – Mile 18.8

Original Construction Date	1948 (Steel Girders). 1972 (Timber Trestles)
Inspection Date	May 12, 2025
Previous Inspection Date	N/A
Total Length	197' (60.0m)
Bridge Design Load	E-60 (CP Form 925)

Table 3-19: Bridge – Mile 18.8

Feature Crossed	Dry
Superstructure	Timber Frame Trestles and Through Plate Girders
Substructure	Concrete Abutments, Concrete Piers, and Square Timber Column Bents
Track Alignment	Tangent
Rail Weight	Unknown
Track Gradient	1.50%

Figure 3-28: Bridge General Arrangement Drawing – Mile 18.8

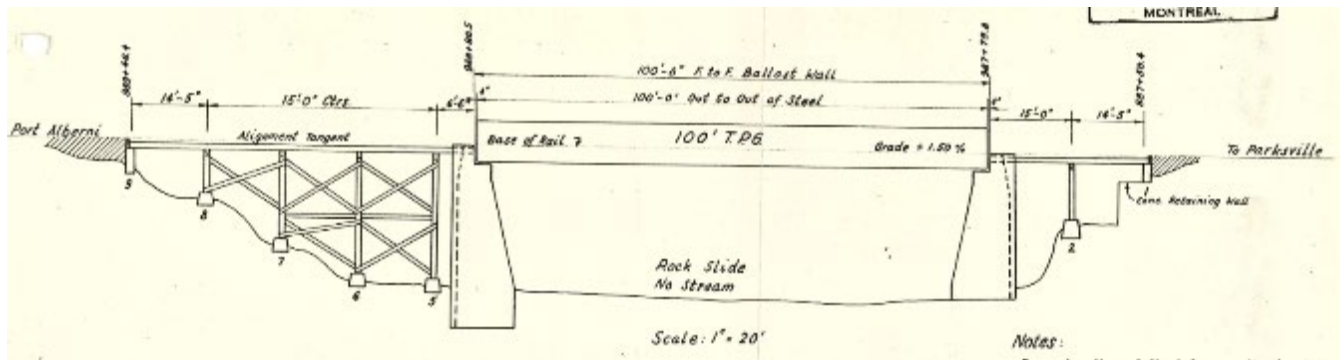

Figure 3-29: Bridge at Mile 18.8 – Deck View Looking West



Figure 3-30: Bridge at Mile 18.8 – Concrete Abutment



Figure 3-31: Bridge at Mile 18.8 – Top View



3.11.1 General Observations and Ratings

Approaches/Track Surface

- Approaches on either side of the bridge are in fair condition.

Bridge Deck

- Deck ties and guard timbers are in fair condition.
- Running and Jordan rails are in fair condition.
- Overall, the bridge deck is in fair condition.

Superstructure

- There is minor corrosion with no pitting on the girders.
- The bottom flanges of the girders are covered with moss and debris.
- Overall, the superstructure is in fair condition.

Substructure

- Bearings for the through plate girder are in fair condition.
- Concrete abutments and concrete pedestals are covered in moss.
- Bracing, caps, and posts are in fair condition.
- The overall condition of the substructure is fair.

3.11.2 Recommendations and Costs

Overall, the condition of the bridge is considered to be fair with vegetation coverage being the only issue.

The following is a list of recommendations and approximate associated costs:

Table 3-20: Bridge Mile 18.8: Recommendations and Cost

Recommendations	Description	Cost
Brush Clearing Around Bridges	General vegetation clearing around the bridge is recommended where feasible to reduce the risk of timber decay and fire hazard.	\$5,000
Visual Bridge Inspection	It is recommended that annual inspections be conducted on the bridge once the required upgrades are completed for 10-ton hi-rail access. This will ensure the bridge remains in operating condition ahead of any emergency access needs.	N/A
Total (without contingency)		\$5,000

3.12 Mile 20.2

The Mile 20.2 bridge is a 143ft long open deck timber frame trestles bridge crossing over a steep slope. This bridge has not previously been inspected. The underside of the bridge was not accessible due to the steep slopes. The drone was flown at this bridge during the time of inspection.

Table 3-21: Bridge - Mile 20.2

Original Construction Date	1973
Inspection Date	May 12, 2025
Previous Inspection Date	N/A
Total Length	143' (43.6m)
Bridge Design Load	E-60
Feature Crossed	Dry
Superstructure	Timber -Frame Trestle
Substructure	Concrete Abutment and Square Timber Column Bents with Concrete Foundations
Track Alignment	4°-00' Curve
Rail Weight	100lb
Track Gradient	1.20%

Figure 3-32: Bridge General Arrangement Drawing - Mile 20.2

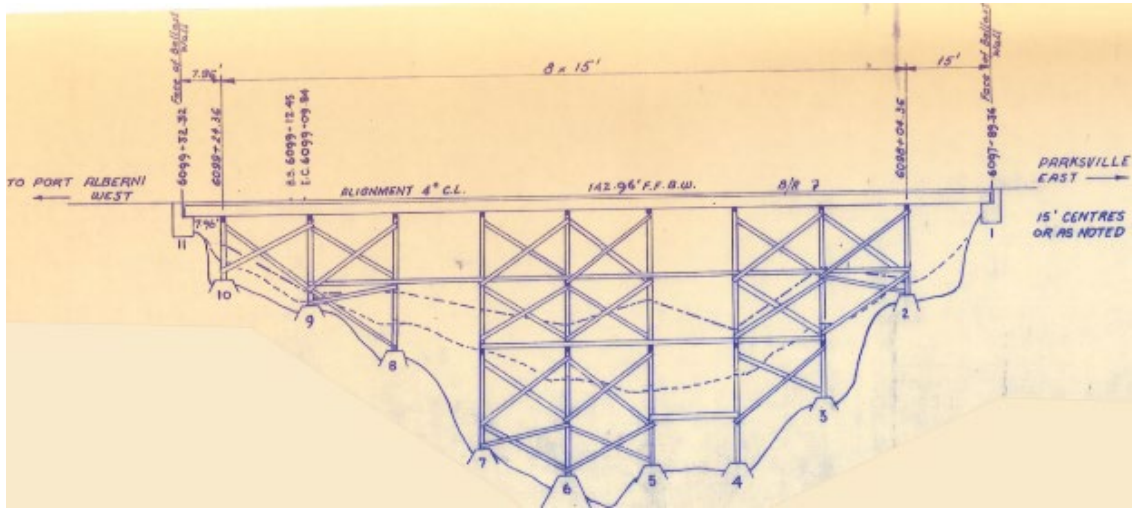

Figure 3-33: Bridge at Mile 20.2 – Deck View Looking West



Figure 3-34: Bridge at Mile 20.2 – South Elevation



3.12.1 General Observations and Ratings

Approaches/Track Surface

- Approaches on either side of the bridge are in fair condition.

Bridge Deck

- Deck ties and guard timbers are in fair condition aside from one section of guard timber that needs to be replaced.
- Running and Jordan rails are in fair condition.
- There is heavy moss coverage between the north running rail and the Jordan rail.
- Refuge bay is in poor condition.
- Overall, the bridge deck is in fair condition.

Superstructure

- No defects noted on the stringers.
- Overall, the superstructure is in fair condition.

Substructure

- No defects noted in the bent caps.
- Concrete pedestals are covered in vegetation and are unobservable.
- Bracing and posts are in fair condition.
- The overall condition of the substructure is fair.

3.12.2 Recommendations and Costs

Overall, the condition of the bridge is considered to be fair, with only minor items requiring replacement.

The following is a list of recommendations and approximate associated costs:

Table 3-22: Bridge Mile 20.2: Recommendations and Cost

Recommendations	Description	Cost
Replace Section of Guard Rail	There is one stretch of guard rail that is damaged and is recommended to be replaced.	\$1,000
Brush Clearing Around Bridges	General vegetation clearing around the bridge is recommended where feasible to reduce the risk of timber decay and fire hazard.	\$10,000
Visual Bridge Inspection	It is recommended that annual inspections be conducted on the bridge once the required upgrades are completed for 10-ton hi-rail access. This will ensure the bridge remains in operating condition ahead of any emergency access needs.	N/A
Total (without contingency)		\$11,000

3.13 Mile 21.4

The Mile 21.4 bridge is a 210ft long open deck timber pile trestle bridge crossing through a section of Summit Lake. The underside of the bridge was not accessible due to water body under the bridge. The drone was flown at this bridge during the time of inspection.

Table 3-23: Bridge - Mile 21.4

Original Construction Date	1911. Most recently replaced 1970
Inspection Date	May 12, 2025
Previous Inspection Date	August 15, 2019
Total Length	210' (64.0m)
Bridge Design Load	E-60
Feature Crossed	Summit Lake
Superstructure	Timber Pile Trestle
Substructure	Round Timber Pile Bents
Track Alignment	Tangent
Rail Weight	100lb
Track Gradient	1.60%

Figure 3-35: Bridge General Arrangement Drawing - Mile 21.4

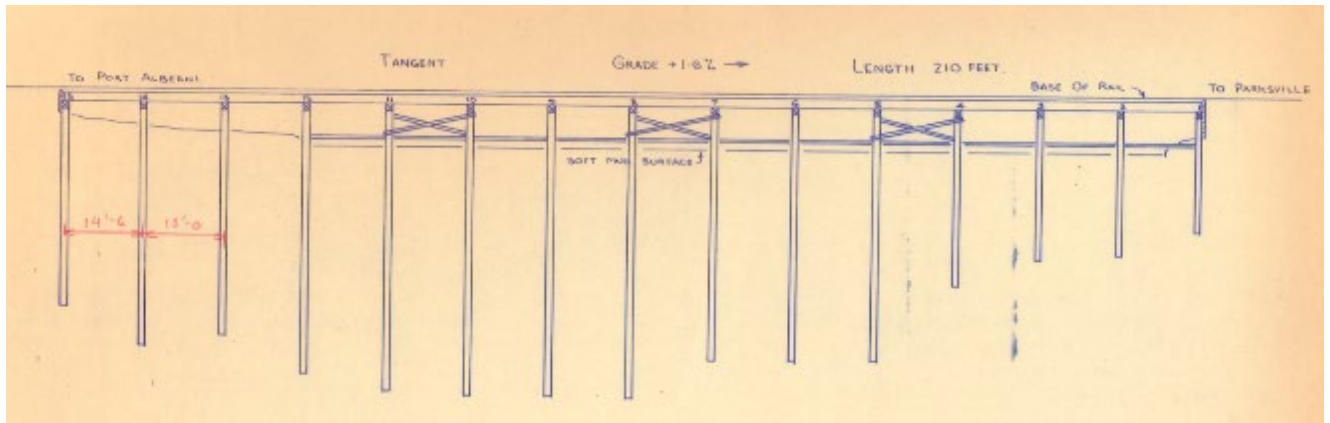

Figure 3-36: Bridge at Mile 21.4 – Deck View Looking East



Figure 3-37: Bridge at Mile 21.4 – Aerial View Looking North



3.13.1 General Observations and Ratings

Approaches/Track Surface

- Approaches on either side of the bridge are in fair condition.

Bridge Deck

- Entire bridge deck is in fair condition.
- Running and Jordan rails are in fair condition.

Superstructure

- No defects noted on the stringers.
- Overall, the superstructure is in fair condition.

Substructure

- Bent caps, bracing, and posts are in fair condition.
- The overall condition of the substructure is fair.

3.13.2 Recommendations and Costs

Overall, the condition of the bridge is considered to be fair, with no elements showing significant further deterioration compared to the previous 2019 inspections.

The following is a list of recommendations and approximate associated costs:

Table 3-24: Bridge Mile 21.4: Recommendations and Cost

Recommendations	Description	Cost
Replace Timber Retaining Wall and Post Split Pile	As noted in the 2019 WSP inspection report, the timber retaining wall on the south end of the bridge is decayed and should be replaced. The WSP report also noted Pile 3 on the (south bent) east bent is split and requires replacement.	\$27,000
Brush Clearing Around Bridges	General vegetation clearing and removal at debris in the waterway around the bridge ends is recommended where feasible.	\$4,000
Visual Bridge Inspection	It is recommended that annual inspections be conducted on the bridge once the required upgrades are completed for 10-ton hi-rail access. This will ensure the bridge remains in operating condition ahead of any emergency access needs.	N/A
Total (without contingency)		\$31,000

3.14 Mile 21.8

The Mile 21.8 bridge is a 482ft long open deck timber pile trestle bridge crossing through a section of Loon Lake. The underside of the bridge was not accessible due to the marshy land underneath the bridge. A drone flight was conducted at the bridge at the time of inspection.

Table 3-25: Bridge - Mile 21.8

Original Construction Date	1962
Inspection Date	May 13, 2025
Previous Inspection Date	August 15, 2019
Total Length	482' (146.9m)
Bridge Design Load	E-50
Feature Crossed	Loon Lake
Superstructure	Timber Pile Trestle
Substructure	Round Timber Pile Bents
Track Alignment	Tangent
Rail Weight	80lb
Track Gradient	-1.50%

Figure 3-38: Bridge General Arrangement Drawing - Mile 21.8

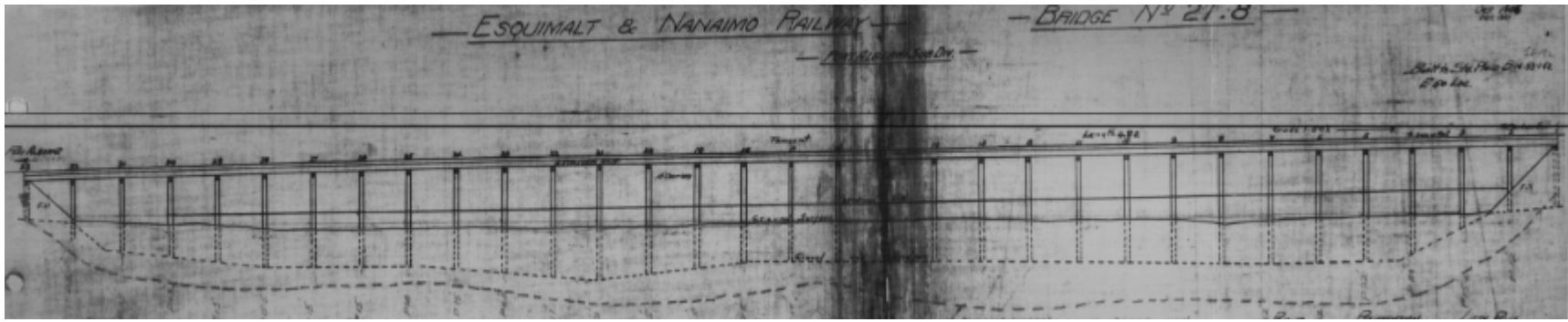

Figure 3-39: Bridge at Mile 21.8 – Deck View Looking East



Figure 3-40: Bridge at Mile 21.8 – Under Side View Looking East



3.14.1 General Observations and Ratings

Approaches/Track Surface

- Approaches on either side of the bridge are in fair condition.

Bridge Deck

- 25% of the deck ties are in poor condition.
- A section of guard timber is missing on the north side near bent 1.
- Running and Jordan rails are in fair condition.
- Refuge bays are observed to be missing handrails.
- The bridge deck is in fair condition, with the exception of the ties that need to be replaced.

Superstructure

- The bridge has 3 chord stringers. Stringer 1 shows signs of decay and is noted to be in poor condition.
- Overall, the superstructure is in fair condition.

Substructure

- The bent caps are showing signs of decay and are in fair to poor condition. 15% of caps are in poor condition.
- Bracing and posts are in fair condition.
- The overall condition of the substructure is fair.

3.14.2 Recommendations and Costs

Overall, the condition of the bridge is considered to be fair, with no elements showing significant further deterioration compared to the previous 2019 inspections.

The following is a list of recommendations and approximate associated costs:

Table 3-26: Bridge Mile 21.8: Recommendations and Cost

Recommendations	Description	Cost
Replacement of 25% of Deck Ties	About 25% of the deck ties were noted to be in poor condition and need to be replaced.	\$78,325
Replace Section of Guard Timber	There is a section of guard rail that is missing and needs to be replaced.	Included in tie replacement cost.
Post Pile 5, Bent 32	WSP noted that pile 5 at bent 32 is split, has failed, and should be posted.	\$7,000
Brush Clearing Around Bridges	General vegetation clearing and removal at debris in the waterway around the bridge ends is recommended where feasible.	\$4,000
Visual Bridge Inspection	It is recommended that annual inspections be conducted on the bridge once the required upgrades are completed for 10-ton hi-rail access. This will ensure the bridge remains in operating condition ahead of any emergency access needs.	N/A
Total (without contingency)		\$89,325

3.15 Mile 22.1

The Mile 22.1 bridge is a 120ft long open deck timber pile trestle bridge crossing through a section of Loon Lake. The underside of the bridge was not accessible due to the water body under the bridge. A drone flight was conducted at the bridge at the time of inspection.

Table 3-27: Bridge - Mile 22.1

Original Construction Date	1976
Inspection Date	May 13, 2025
Previous Inspection Date	August 15, 2019
Total Length	120' (36.6m)
Bridge Design Load	E-60
Feature Crossed	Loon Lake
Superstructure	Timber Pile Trestle
Substructure	Round Timber Pile Bents
Track Alignment	Tangent to 10°-00' Curve
Rail Weight	85lb
Track Gradient	-1.37%

Figure 3-41: Bridge General Arrangement Drawing - Mile 22.1

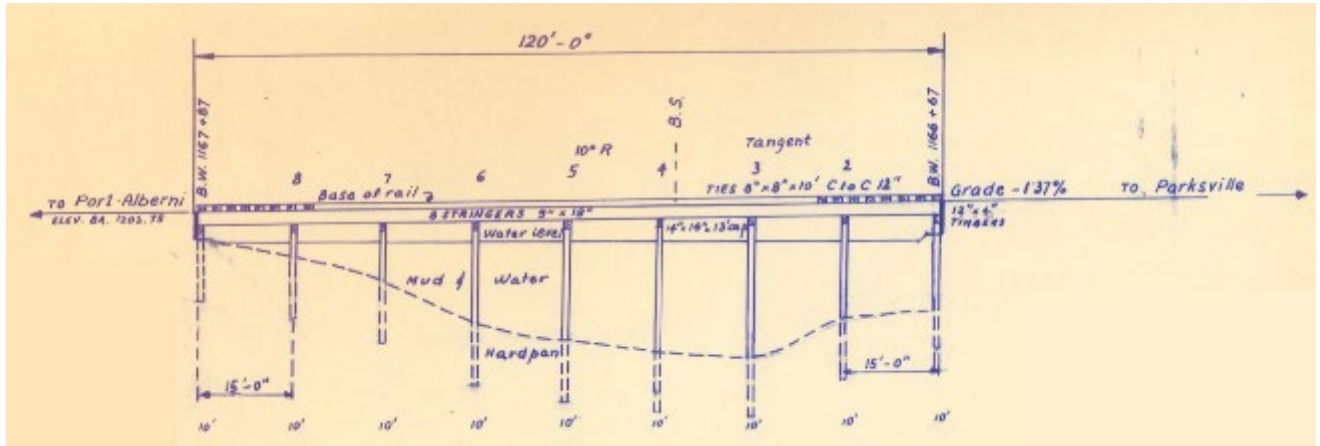

Figure 3-42: Bridge at Mile 22.1 – Deck View Looking West



Figure 3-43: Bridge at Mile 22.1 – Fire Damage



Figure 3-44: Bridge at Mile 22.1 – Debris Build up in North Side



3.15.1 General Observations and Ratings

Approaches/Track Surface

- Approaches on either side of the bridge are in fair condition.

Bridge Deck

- The north section of the deck -has fire damage to the ties and guard timber.
- The ties are showing signs of deterioration due to the water level.
- Running and Jordan rails are in fair condition.
- The bridge deck is in fair condition.

Superstructure

- The stringers have moss coverage.
- Overall, the superstructure is in fair condition.

Substructure

- There is debris build-up on the north end of the bridge.
- Bracing and posts are in fair condition.
- The overall condition of the substructure is fair.

3.15.2 Recommendations and Costs

Overall, the condition of the bridge is considered to be fair, and aside from the fire damage there are no elements showing significant further deterioration compared to the previous 2019 inspection.

The following is a list of recommendations and approximate associated costs.

Table 3-28: Bridge Mile 22.1: Recommendations and Cost

Recommendations	Description	Cost
Replacement of Burnt Deck Ties and Guard Timber	The deck ties with fire damage should be replaced.	\$1,950
Debris Cleaning	There is debris build-up on the north side of the bridge that should be removed to allow flow of water under the bridge.	\$3,000
Visual Bridge Inspection	It is recommended that annual inspections be conducted on the bridge once the required upgrades are completed for 10-ton hi-rail access. This will ensure the bridge remains in operating condition ahead of any emergency access needs.	N/A
Total (without contingency)		\$4,950

3.16 Mile 25.0

The Mile 25.0 bridge is a 346ft long open deck timber frame trestle bridge crossing over a steep slope. The underside of the bridge was not accessible due to the steep slopes. A drone flight was conducted at the bridge the time of inspection.

Table 3-29: Bridge - Mile 25.0

Original Construction Date	1953
Inspection Date	May 13, 2025
Previous Inspection Date	August 15, 2019
Total Length	346' (105.5m)
Bridge Design Load	E-50
Feature Crossed	Dry
Superstructure	Timber Frame Trestle
Substructure	Square Timber Columns
Track Alignment	Tangent
Rail Weight	85lb
Track Gradient	-1.50%

Figure 3-45: Bridge General Arrangement Drawing - Mile 25.0

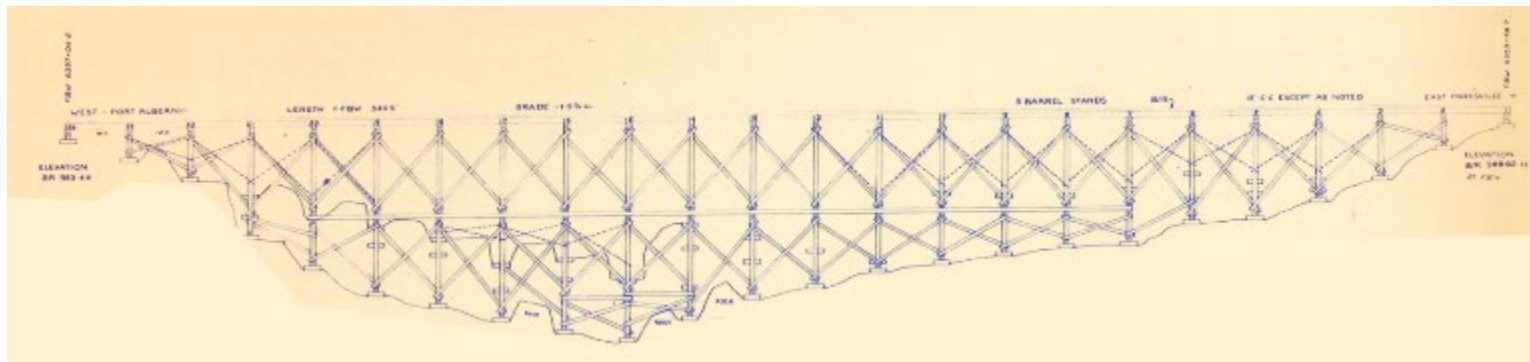

Figure 3-46: Bridge at Mile 25.0 – Deck View Looking West



Figure 3-47: Bridge at Mile 25 – South Elevation



Figure 3-48: Bridge at Mile 25.0 – Mud Sill Decay



Figure 3-49: Bridge at Mile 25.0 – Failed Cap and Brace



3.16.1 General Observations and Ratings

Approaches/Track Surface

- Approaches on either side of the bridge are in fair condition.

Bridge Deck

- Track alignment is observed to have lateral deviations throughout the bridge.
- Most deck ties are in poor condition and 90% need to be replaced.
- Running and Jordan rails are in fair condition.
- The bridge deck is in poor condition.

Superstructure

- Stringers are fair to poor condition.
- Overall, the superstructure is in fair to poor condition.

Substructure

- Bent caps are in fair condition.
- Posts are in fair condition.
- Various braces are broken or split.
- There is a large amount of vegetation growth at the base of the bents.
- The sills are rated as fair to poor, with poor sills showing severe deterioration, some completely crushed.
- The overall condition of the substructure is poor to fair.

3.16.2 Recommendations and Costs

Overall, the condition of the bridge is considered to be fair, and aside from the fire damage, there are no elements showing significant further deterioration compared to the previous 2019 inspection.

The following is a list of recommendations and approximate associated costs:

Table 3-30: Bridge Mile 25.0: Recommendations and Cost

Recommendations	Description	Cost
Replace Deck Ties	The majority of deck ties are in poor condition and are recommended to be replaced.	\$224,900
Replace Mud Sills	The mud sills seen are deteriorating or completely crushed which could be the cause to the wavy track alignment. The condition of all mud sills could not be determined due to vegetation growth but it has been assumed that 50% of the mud sills are required.	\$106,000
Brush Clearing Around Bridges	General vegetation clearing around the bridge is recommended where feasible to reduce the risk of timber decay and fire hazard.	\$10,000
Visual Bridge Inspection	It is recommended that annual inspections be conducted on the bridge once the required upgrades are completed for 10-ton hi-rail access. This will ensure the bridge is in operating condition ahead of any emergency access needs.	N/A
Total (without contingency)		\$340,900

3.17 Mile 28.9

The Mile 28.9 bridge is a 46.5ft long open deck timber stringer superstructure bridge crossing over a slope. The underside of the bridge was not accessible due to the steep slopes. A drone flight was not conducted at the bridge as the area is overgrown with vegetation.

Table 3-31: Bridge - Mile 28.9

Original Construction Date	1942 (abutments and piers), 1962 (superstructure Rehabilitation), 1987 (Added piers)
Inspection Date	May 13, 2025
Previous Inspection Date	N/A
Total Length	75'
Bridge Design Load	E-60
Feature Crossed	Dry
Superstructure	Timber Stringers
Substructure	Concrete Abutments and Piers
Track Alignment	2°-00' Curve
Rail Weight	100lb
Track Gradient	-1.6%

Figure 3-50: Bridge General Arrangement Drawing - Mile 28.9

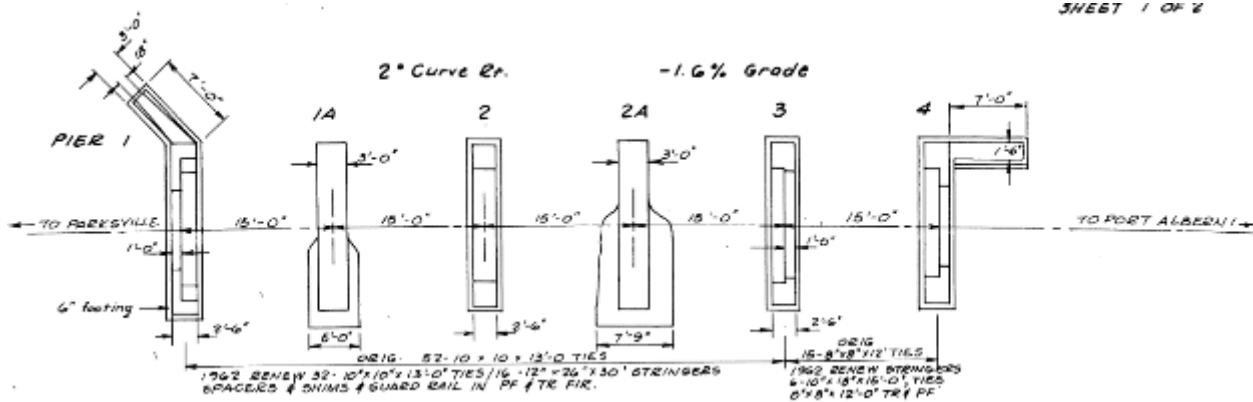

Figure 3-51: Bridge at Mile 28.9 – Deck View Looking East



3.17.1 General Observations and Ratings

Approaches/Track Surface

- Approaches on either side of the bridge are in fair condition.

Bridge Deck

- Deck ties and guard timbers are in fair condition.
- Running and Jordan rails are in fair condition.
- Overall, the bridge deck is in fair condition.

Superstructure

- Stringers are in fair condition.
- Overall, the superstructure is in fair condition.

Substructure

- Concrete piers and abutments were noted to be in fair condition.
- The overall condition of the substructure is fair.

3.17.2 Recommendations and Costs

Overall, the condition of the bridge is considered to be fair, with only vegetation overgrowth being a minor issue.

The following is a list of recommendations and approximate associated costs:

Table 3-32: Bridge Mile 28.9: Recommendations and Cost

Recommendations	Description	Cost
Brush Clearing Around Bridges	General vegetation clearing around the bridge is recommended where feasible to reduce the risk of timber decay and fire hazard.	\$3,000
Visual Bridge Inspection	It is recommended that annual inspections be conducted on the bridge once the required upgrades are completed for 10-ton hi-rail access. This will ensure the bridge remains in operating condition ahead of any emergency access needs.	N/A
Total (without contingency)		\$3,000

3.18 Mile 29.9

The Mile 29.9 bridge is a 300ft long open deck timber frame trestle bridge crossing over an unnamed waterway. The underside of the bridge was not accessible due to the steep slopes. A drone flight was conducted at this bridge at the time of inspection.

Table 3-33: Bridge - Mile 29.9

Original Construction Date	1953
Inspection Date	May 13, 2025
Previous Inspection Date	N/A
Total Length	300' (91.4m)
Bridge Design Load	E-50
Feature Crossed	Unnamed Waterway
Superstructure	Timber Stringers
Substructure	Square Timber Column Bents
Track Alignment	Tangent to 8°-00' Curve
Rail Weight	85lb
Track Gradient	-1.38%

Figure 3-52: Bridge General Arrangement Drawing - Mile 29.9

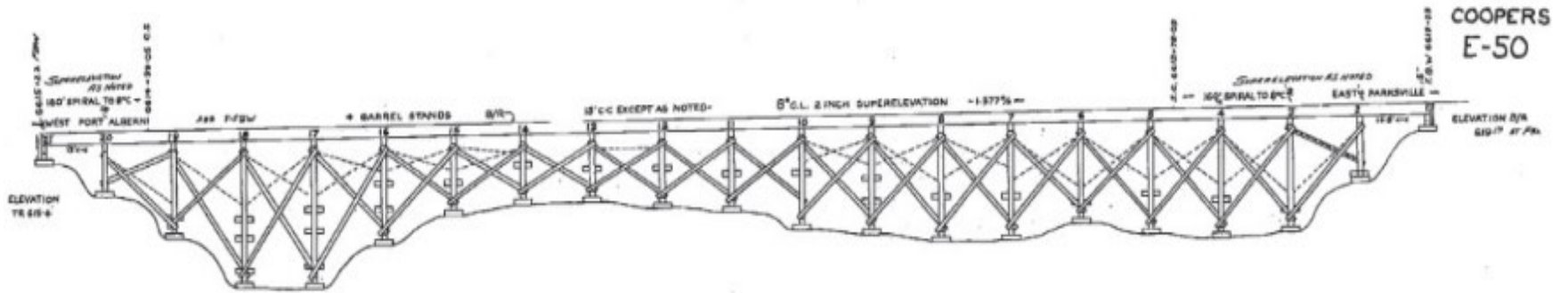

Figure 3-53: Bridge at Mile 29.9 – Deck View Looking West



Figure 3-54: Bridge at Mile 29.9 – Side View Looking West



Figure 3-55: Bridge at Mile 29.9 – Decayed Mud Sills – Post 3, Bent 7



3.18.1 General Observations and Ratings

Approaches

- Approaches on either side of the bridge are in fair condition.

Bridge Deck

- Refuge bays are decayed and in poor condition.
- A large number of deck ties are fully decayed with the others in poor condition and in need of replacement.
- The guard timbers are covered in moss but in fair condition.
- The bridge deck is in poor condition.

Superstructure

- Stringers are in fair condition with no concerns noted.
- Overall, the superstructure is in fair condition.

Substructure

- Bent caps are in fair condition with no concerns noted.
- Mud sills are in fair to poor condition. Some are deteriorating as they are in the splash zone of the waterway.
- Mud sills are undermined at Bent 3-Post 1 and at Bent 7-Post 3.
- Mud sills at Bent 8-Post 3&4 have minor decay.
- Cribbing at mud sills at Post 3 – Bent 7 and 8 have severe decay.
- Mud sills at Bent 10-Post 3&4 are settling and leaning north.
- Braces were in fair condition overall, except for one that was observed to be split.
- The overall condition of the substructure is fair to poor.

3.18.2 Recommendations and Costs

Overall, the condition of the bridge is considered to be fair to poor due to the poor condition of the deck and sills.

The following is a list of recommendations and approximate associated costs:

Table 3-34: Bridge Mile 29.9: Recommendations and Cost

Recommendations	Description	Cost
Replace Deck Ties	The majority of deck ties are in poor condition and are recommended to be replaced.	\$195,000
Replace Mud Sills	Various mud sills are deteriorating or undermined. Replacement of two of the mud sills at Bent 7 and 8 is recommended.	\$4,000
Brush Clearing Around Bridges	General vegetation clearing around the bridge is recommended where feasible to reduce the risk of timber decay and fire hazard.	\$10,000
Visual Bridge Inspection	It is recommended that annual inspections be conducted on the bridge once the required upgrades are completed for 10-ton hi-rail access. This will ensure the bridge remains in operating condition ahead of any emergency access needs.	N/A
Total (without contingency)		\$209,000

3.19 Mile 36.5

The Mile 36.5 bridge is a 228ft long deck plate girder / deck truss bridge crossing over Kitsuksus Creek. A drone flight was conducted at the time of inspection.

Table 3-35: Bridge - Mile 36.5

Original Construction Date	1911 (Deck Truss), 1927 (West-span), and 1928 (East span)
Inspection Date	May 13, 2025
Previous Inspection Date	August 15, 2019
Total Length	228' (69.5m)
Bridge Design Load	E-50 (per SVI inventory, not confirmed)
Feature Crossed	Kitsuksus Creek
Superstructure	Deck Plate Girders and Deck Truss
Substructure	Concrete Abutment and Piers
Track Alignment	6°-00' Curve
Rail Weight	85lb
Track Gradient	-1.37%

Figure 3-56: Bridge General Arrangement Drawing - Mile 36.5

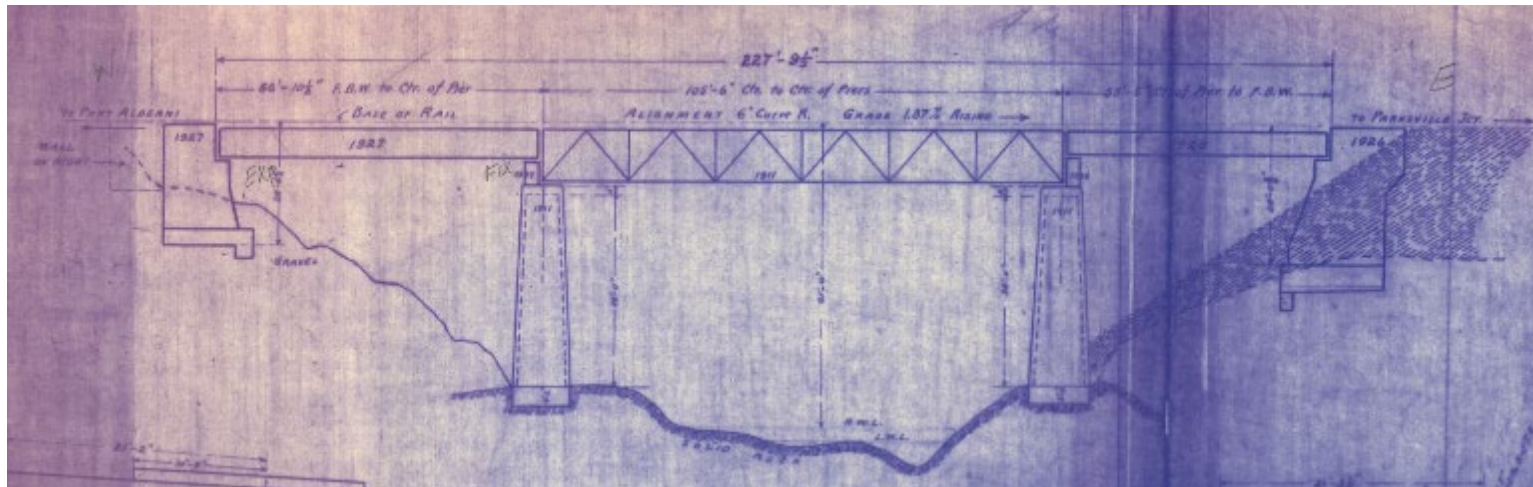

Figure 3-57: Bridge at Mile 36.5 – Deck View Looking East



Figure 3-58: Bridge at Mile 36.5 – Birds Eye View



Figure 3-59: Bridge at Mile 36.5 – West Pier



3.19.1 General Observations and Ratings

Approaches/Track Surface

- Approaches on either side of the bridge are in fair condition.

Bridge Deck

- The bridge deck is in fair condition.
- Running and Jordan rails are in fair condition.

Superstructure

- Span 1 - Deck Plate Girder:
 - Up to 1/4" pitting on horizontal surface.
 - Surface rust throughout.
- Span 2 - Deck Truss:
 - Up to 1/8" pitting on horizontal surface.
 - Surface rust throughout.
 - The south-west bearing anchor bolt on Pier 2 is raised and coming off the bearing plate.
 - Bottom chord does not have any drainage as it has a bottom cover plate and is full of debris.
- Span 3 - Deck Plate Girder:
 - Up to 1/4" pitting on horizontal surface.
 - Surface rust throughout.
- Overall, the superstructure is in fair condition.

Substructure

- Concrete piers appear to be in fair condition.
- The overall condition of the substructure is fair.

3.19.2 Recommendations and Costs

Overall, the condition of the bridge is considered to be fair with only minor items to address. There is no further deterioration or items of concern compared to the previous 2019 inspection.

The following is a list of recommendations and approximate associated costs:

Table 3-36: Bridge Mile 36.5: Recommendations and Cost

Recommendations	Description	Cost
Replace Bearing Anchor Bolts	The bearing anchor bolts have lifted out at the SW bearing of Pier 2 and should be replaced.	\$10,000
Brush Clearing Around Bridges	General vegetation clearing around the bridge is recommended where feasible to reduce the risk of timber decay and fire hazard.	\$5,000
Visual Bridge Inspection	It is recommended that annual inspections be conducted on the bridge once the required upgrades are completed for 10-ton hi-rail access. This will ensure the bridge remains in operating condition ahead of any emergency access needs.	N/A
Total (without contingency)		\$15,000

3.20 Mile 37.1

The Mile 37.1 bridge is a 151.5ft long deck plate girder bridge crossing over Roger Creek. A drone flight was conducted at the bridge at time of inspection.

Table 3-37: Bridge - Mile 37.1

Original Construction Date	Unknown
Inspection Date	May 13, 2025
Previous Inspection Date	August 15, 2019
Total Length	151.5' (46.2m)
Bridge Design Load	E-50
Feature Crossed	Roger Creek
Superstructure	Deck Plate Girder
Substructure	Concrete Abutments and Piers
Track Alignment	6°-00' Curve
Rail Weight	85lb
Track Gradient	-1.40%

Figure 3-60: Bridge General Arrangement Drawing - Mile 37.1

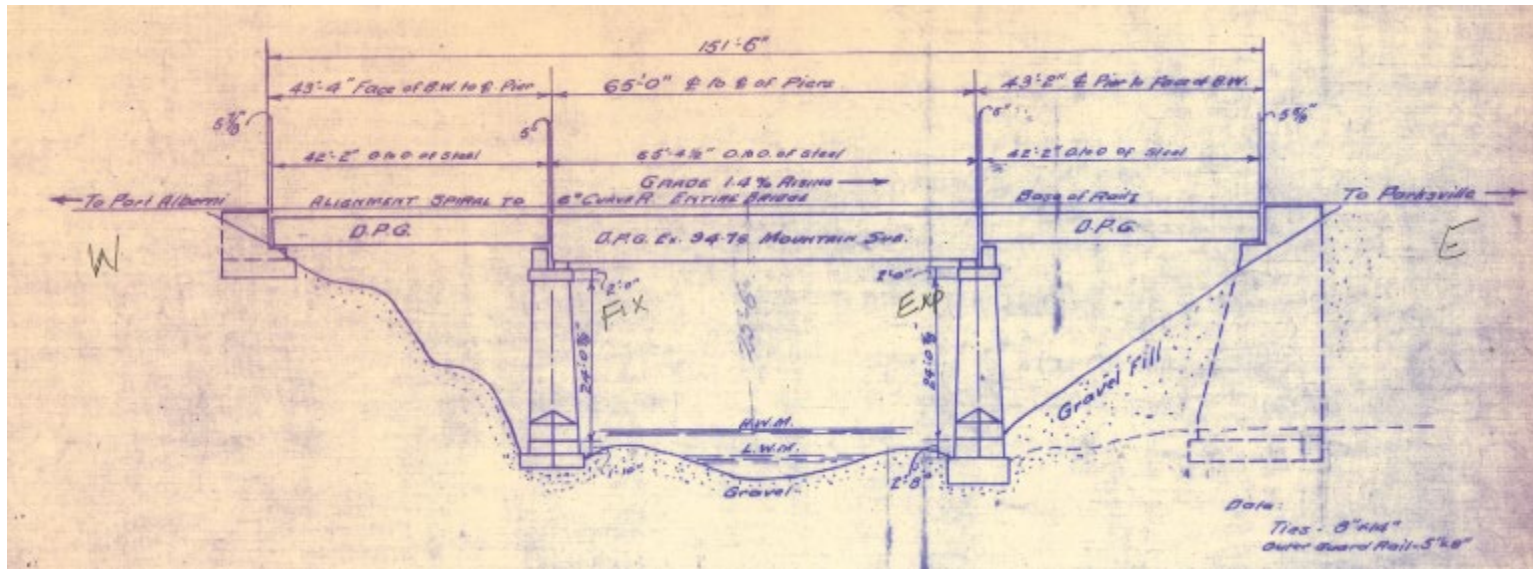

Figure 3-61: Bridge at Mile 37.1 – Deck View Looking West



Figure 3-62: Bridge at Mile 37.1 – Pier View



Figure 3-63: Bridge at Mile 37.1 – Pier 2 Foundation Minor Scour



3.20.1 General Observations and Ratings

Approaches

- Approaches on either side of the bridge are in fair condition.
- Minor ballast loss and undermining at end of ties at east abutment, north side.

Bridge Deck

- Running rail and Jordan rail are observed to be in fair condition.
- The bridge deck is in fair condition.

Superstructure

- Span 1 - Deck Plate Girder:
 - Up to 3/16" pitting on gussets/cover plates.
 - Girder 2 has an 8" shim on top of the top flange cover plates.
 - Pack rust was observed On girder 2 cover plates.
 - Surface rust throughout.
- Span 2 - Deck Plate Girder:
 - Up to 1/4" pitting on horizontal surface.
 - The top lateral at Bay 3 is twisted and damaged.
- Span 3 - Deck Plate Girder:
 - Timber shims on girder 1 (north).
 - Up to 3/16" pitting on gussets/cover plates.
 - On girder 2 cover plates pack rust was observed.
 - Surface rust throughout.
- Overall, the superstructure is in fair condition.

Substructure

- Concrete piers / abutments appear to be in fair condition.
- Minor scouring on foundation of Pier 2 observed.
- The overall condition of the substructure is fair.

3.20.2 Recommendations and Costs

Overall, the condition of the bridge is considered to be fair with only minor items to address. There is no further deterioration or items of concern compared to the previous 2019 inspections.

The following is a list of recommendations and approximate associated costs:

Table 3-38: Bridge Mile 36.5: Recommendations and Cost

Recommendations	Description	Cost
Brush Clearing Around Bridges	General vegetation clearing around the bridge is recommended to provide proper sightlines for vehicles operating over the bridge and to facilitate further inspection and rehabilitation of the bridge.	\$3,000
Visual Bridge Inspection	It is recommended that annual inspections be conducted on the bridge once the required upgrades are completed for 10-ton hi-rail access. This will ensure the bridge remains in operating condition ahead of any emergency access needs.	N/A
Total (without contingency)		\$3,000

4 References

- 2020 WSP - Island Rail Corridor Condition Assessment – Track Condition Assessment
- 2020 WSP - Island Rail Corridor - Bridge Assessment
- 2022 WSP – Bridge Load Ratings Port Alberni Subdivision Mileage 13.7, 13.8, 14.0, 14.6
- AREMA Bridge Inspection Handbook

Appendix A: Track Condition Summary Table

Appendix B: Bridge Condition Summary Table

Appendix C: Port Alberni Subdivision – Track Chart

Appendix D: Port Alberni Subdivision – Culvert List