



Alberni-Clayoquot Regional District

WEST COAST COMMITTEE MEETING
THURSDAY, JANUARY 26, 2017, 3:00 PM
UCLUELET COMMUNITY CENTER – ACTIVITY ROOM #1
500 Matterson, Ucluelet, BC

REVISED AGENDA

	PAGE #
1. <u>CALL TO ORDER (CAO)</u>	
Recognition of Traditional Territories.	
2. <u>APPROVAL OF AGENDA</u>	
<i>(motion to approve, including late items requires 2/3 majority vote)</i>	
Late Business:	
3 (a) West Coast Multiplex Society and Tla-o-qui-aht First Nation Letter	
4 (c) West Coast Multiplex 2016 Expenditures	
3. <u>CORRESPONDENCE</u>	
a. West Coast Multiplex Society and Tla-o-qui-aht First Nation letter	2
4. <u>REPORTS</u>	
a. West Coast Multi Plex Business Case Review and Next Steps discussion with representatives of the West Coast Multi Plex Society and Tla-o-qui-aht First Nation	3-63
b. VIU Public Opinion Poll –Merits/Details discussion Pam Shaw via Conference Call 3:30 pm	
c. West Coast Multiplex 2016 Expenditure	64
5. <u>LATE BUSINESS</u>	
6. <u>ADJOURN</u>	



WEST COAST
· MULTIPLEX ·

Dear West Coast Committee,

Thanks for your recent decision to approve the next steps in the design and costing portion of the West Coast Multiplex Project. When completed, we will all be able to properly estimate capital and ongoing operating /maintenance costs. Finally, there will be a design of the proposed facility to share with local residents.

However, we understand that there is a desire to hire Vancouver Island University to undertake a "Pulse-check" of west coast residents to determine support for the project.

We appreciate the concern over potential changes in attitude over the 4 years since the referendum. However, we respectfully submit that a survey should not take place until we have a final phase 1 design and costing information in place. Local residents should have the most up to date information by which to make an educated decision. Further, we also would like input into the design of the survey that could have a significant effect on the proposed facility.

Therefore we ask that the "Pulse-check" take place after the other stages are complete and when accurate costing information can be shared with local residents.

We also ask that we be involved in all elements of the redesign, including the development of operating and maintenance costs. For example, we believe there are revenue streams that were not addressed in the Rec Excellence report that should be included.

We think a specific design that will meet local needs, can offer significant capital cost savings. Currently, the capital costs being presented are those of Shawnigan Lake School.

We are providing this ahead of the January 26th Meeting, such that everyone can be prepared to discuss this and give their thoughts at the meeting, to allow for an expedient address of the next-steps.

At that meeting it would also be helpful to have an up-to-date accounting of the \$100,000 that was provided for this project.

Sincerely,



Samantha Hackett
Chair - WCMS



Ted Adnitt
TFN for Chief Elmer Frank

West Coast Multi Plex Phase 1 – The Arena Feasibility Study

rec
RECREATION **ex** EXCELLENCE
“Serious about fun”

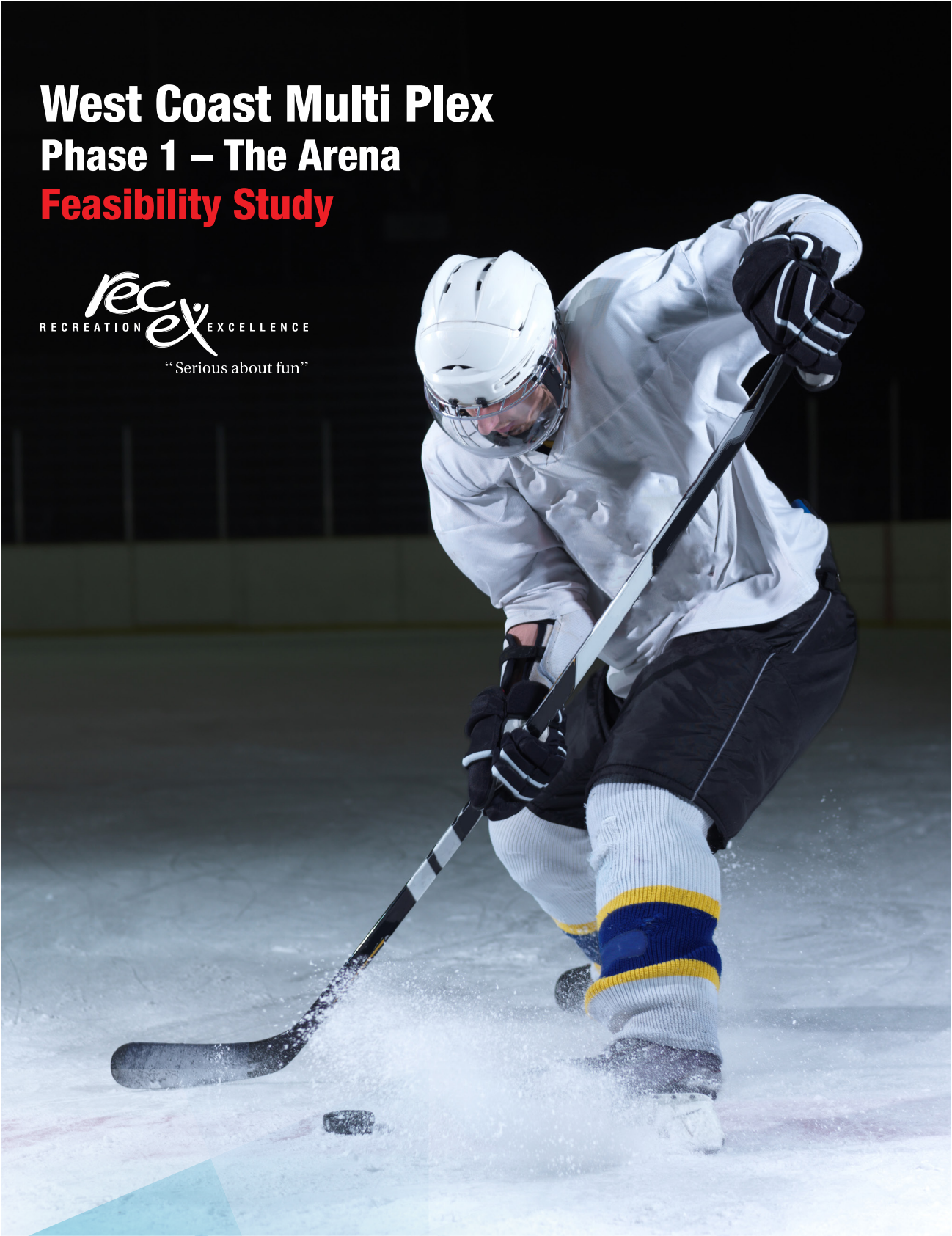

Table of Contents

Introduction	3
Executive Summary	6
The Facility, Capital Costs and Comparisons and Funding.....	8
Refrigeration Systems	15
Management and Operational Models	18
Staffing	25
Use.....	27
Budget	42
Operational Budget Comparisons	48
Future Aquatic Centre	52
APPENDIX	
Arena Floor Plans	53

Introduction

The Tla-o-qui-aht First Nation received funding through Indigenous and Northern Affairs Canada to develop a Feasibility Study on building and operating an ice and dry floor arena as the first stage of a Multi Plex recreational facility in the West Coast Communities. Tla-o-qui-aht sees the facility as a potential economic generator for their community, as a potential business and employment centre, as a draw to families to settle in the community and as a potential meeting place for large gatherings that will provide cultural and economic opportunities.

Previous reports have been completed for the West Coast Communities and for each of Tofino and Ucluelet, dealing with a variety of options for constructing and sustaining recreation facilities. Recently Ucluelet constructed the Ucluelet Community Centre, providing local and efficient delivery of services for meetings and conferences that would have previously been considered for a Multi Plex.

In 2008, the West Coast Multi Plex Society engaged Recreation Excellence to prepare a report, presented to the CAO of Tofino, which concluded that an arena/pool Multi Plex would require an investment of approximately \$17 million to build and ready for opening. Both the capital costs and the net operating costs projected were beyond what the Communities could bear at that time.

There has been a number of studies and proposals produced subsequent to the 2008 Recreation Excellence report; this study makes use of the information gathered in 2008, but does not rely on it. Moving to a rink-first approach, the design, construction and operational approach requires a new look at operational plans and options.

The referendum on the West Coast Multi Plex Service Area Establishment held in 2012 was approved to operate a recreation facility including a multiplex facility, with an annual maximum requisition limit of the greater of \$450,000 or \$0.335 per \$1,000 of taxable value of land and improvements.

There is no mechanism to tax the five First Nation Communities, the other stakeholder population within this facility's catchment.

Administration of this study is being conducted through the Alberni-Clayoquot Regional District (ACRD), which has contracted retired Port Alberni Director of Parks, Recreation and Culture, Scott Kenny, to work with the West Coast Multi Plex Society, including overseeing the production of the study. In September 2016 Recreation Excellence was contracted to conduct and present the Feasibility Study with presentation of a Draft Report on December 12, 2016, and a Final Report to follow. The mandate was to produce a report considering the construction and operation of an ice rink on the airport property with an aquatic centre to be built later. The aquatic centre was to be considered only minimally (the design to accommodate a later melding, and the operational plan to consider how efficiencies could be prepared).

The potential of the Tla-o-qui-aht First Nation being responsible for, or involved in, the operation of the facility was to be considered as well as other economic benefits the facility could bring.

The Recreation Excellence Consulting Team for this project was led by Peter MacLeod, and drew from senior members of Recreation Excellence.

Recreation Excellence was requested to prepare a report that included:

1. A rough conceptual design of an Ice Facility that would meet the needs of the West Coast Community (Ucluelet, Tofino, Area C of the ACRD and First Nations communities in the catchment areas) which could later be evolved into a full Multi Plex.
2. A construction cost estimate for the provided conceptual design, without going to cost quantifying "C" level.
3. Identifying, considering and recommending as appropriate various management and operations options for the facility.
4. A review of arena design construction types, to include both refrigerated panel construction

- and Sprung Structures, as well as other options.
5. Developing a business plan for the operation of the facility with estimates for levels of use and costs of annual operation.
 6. Identifying potential uses in addition to community ice and dry floor sport use and review opportunities and address specific questions about uses of the ice facility and evaluate the feasibility of various program ideas.

It is recognized by all the stakeholders that community spaces and opportunities for recreational and fitness activities are important to communities. Benefits of recreation and wellness to individuals and to communities are well researched and publicized. The 1997 'Benefits Catalogue', produced by the REThink Group states:

- Recreation and active living are essential to personal health
- Recreation is a key to balanced human development
- Recreation and parks are essential to quality of life
- Recreation reduces self-destructive and anti-social behaviour
- Recreation and parks build strong families and healthy communities
- Recreation reduces health care, social service and police/justice costs
- Recreation and parks are significant economic generators
- Parks, open space and natural areas are essential to ecological survival

Most communities with the population of the West Coast have an ice arena, and many have, or are attempting to build, aquatic centres. The capital costs are high and are often the major consideration as to what a community can afford. The long-term costs of operation, maintenance and repairs dwarf the original investment, however. It is vitally important to provide a facility that will hold up over the years and will attract as many users as possible, to both provide value to the community for the dollars spent and to offset those operational costs.

An ice rink facility and eventual Multi Plex could meet the current and future needs of the communities of Tofino, Ucluelet, Area C and local First Nations, and would add significantly to the overall health and wellness of the residents of the area. The West Coast region, although a worldwide draw for its beauty, has harsh winter conditions with short, wet days, making outdoor recreation for the communities difficult for a large portion of the year. Indoor facilities would definitely be a benefit.

Previously, Recreation Excellence considered the financial cost of a Multi Plex aquatic and ice facility within the communities. An aquatic centre attracts a wider portion of the population; however the ice season coincides with difficult weather in the area and the slower economic season. Also, an ice facility's costs can be controlled more effectively than an aquatic facility, by limiting the weeks of service to match viable rental hours – an additional argument for starting with an ice rink and adding an aquatic centre in the future.

From a practical point of view, no facility will be built, and no facility will be successful, without strong support from the community. Even in cases where unanimity was an issue building the project, support is much stronger once the benefits of the facility are experienced.

The background work and report were completed over a period of two months and several key steps were taken to bring a report forward.

An initial trip to the West Coast that included:

- A meeting with stakeholders including the CAO of the Tla-o-qui-aht First Nation, members of the West Coast Multi Plex Society, ACRD representative Scott Kenny and political representation from both Tofino and Ucluelet.
- A visit to the designated facility location on the Airport Lands.
- A tour of the recently constructed Ucluelet Community Centre, to develop an understanding of the need to plan facilities to have co-operative functions, not competing.
- A meeting with Tla-o-qui-aht First Nation's CAO.
- A tour of the Shawnigan Lake Sprung Structure arena, along with the consultants

Introduction cont.

Hambleton Associates, who have worked with the West Coast Multi Plex Society.

In addition to the research that was completed during the initial trip to Tofino, the consultants completed the following work to generate this report:

- The scope of the facility designed in 2008 by Vic Davies Architecture was adjusted to include a rink only, as the first phase of development. It should be recognized that the facility design is still in “draft” form, but, has been refined to meet the needs of the community using the feedback we received at our initial client meeting.
- Sprung Structures created a design concept proposal and has done significant work to quantify the cost of the structure they are promoting.
- Recreation Excellence researched other rink facilities recently built or currently proposed to use as comparisons.
- Recreation Excellence continued to research the local communities of Tofino, Ucluelet and the surrounding First Nations and rural communities to assess the grass roots needs and possibilities in regards to ice, dry floor programming and special events. Numerous phone conversations were held with community members and others with an interest in the activities and/or operation of the facility.
- Staff of each of the major governances were consulted.
- Many recreation and arena professionals were consulted on design and operational issues.

Recreation Excellence has developed a facility program schedule to reflect as much of the feedback as possible. Estimated operational revenues have been derived from the schedules presented. Facility operational planning has been developed. A projection of the number and level of staffing has been completed and was used to determine staffing costs annually. Estimated facility operational budgets include utilities, maintenance, janitorial, program and a life-cycle maintenance estimate. An estimated “start-up budget” has been developed as well.

Arena design and costs were reviewed and recommendations made on building types, refrigeration systems, and the likely capital costs to be incurred.

Recreation Excellence has completed significant research to provide this report. We feel confident that the report is a clear representation of the project and the communities that are involved. We wish to thank the Tla-o-qui-aht First Nation, the ACRD, Tofino, Ucluelet and the West Coast Multi Plex Society, as well as consultant Scott Kenny for their assistance, time and effort during its development. Without their support and feedback, a comprehensive report could not be developed.

Notes

Executive Summary

The Tla-o-qui-aht First Nation received funding through Indigenous and Northern Affairs Canada to to develop this Feasibility Study.

The Alberni-Clayoqout Regional District (ACRD) administered the process and contracted Recreation Excellence Corporation to provide a Feasibility Study/Business Case to report and make recommendations on:

- The facility needed, rough cost estimates for construction, and recommendations on building and refrigeration types
- Potential management and operating models
- Potential uses for the building
- Anticipated operating costs and revenues, including comparisons to other ice rinks

THE FACILITY

Recreation Excellence concluded that the facility location, at the Airport grounds, is acceptable. It also found the majority of ice rinks built today have prefabricated insulated panels; however Sprung Structures, a soft cover building, is being considered for the West Coast and appears to be, based on the few built so far, a viable and less expensive alternative. The refrigeration system is likely to be ammonia-based; if possible a system with compressors under 25kW is preferred for regulatory purposes.

The capital cost for the entire project is to be raised through the community, and assumedly some grants. The West Coast Multi Plex Society is actively fundraising. As for grants from higher levels of government, local governments are supportive of the project, but have other high-need projects.

The estimated range of potential capital cost for the facility is as follows:

COST ITEMS	RANGE OF ESTIMATES	
	Low	High
Construction Proposal Including Builder's Soft Costs	\$8,613,500	\$11,400,000
Site Servicing	\$1,605,688	\$1,605,688
Owners Insurance and Financing	\$100,000	\$100,000
Owner' Start Up Costs	\$437,030	\$437,030
TOTAL CAPITAL COST	\$10,756,218	\$13,542,718

To ensure 50 per cent of the funds necessary to replace the facility in 60 years' time are in place, it is estimated that \$75,000 will need to be allocated each year.

An ammonia refrigeration systems, and if possible with compressors powered under 25kW each is recommended. All available heat recovery systems are recommended for the West Coast.

MANAGEMENT AND OPERATIONS

The most likely managers and operators for the first phase (rink) would be the Tla-o-qui-out First Nation. This would allow for advantages in wage structure and staffing flexibility, as well as an economic development opportunity for Tla-o-qui-aht. A second choice, at higher cost, would be the ACRD.

Program delivery at the Multi Plex would be a more natural fit for either Ucluelet or Tofino, but the manager would hold the responsibility for programming, so Tla-o-qui-aht, or the ACRD, may deliver programs as well.

The ACRD would remain responsible for the operation and maintain oversight through the budget process and assuring the facility is maintained, through agreed reporting structures.

Executive Summary cont.

Notes

FACILITY USE

The level of support for the facility indicates operating seven days a week, for a 22.5-week ice season. There would be minimal programs during a 12 or 13 week dry floor season, resulting in significant economic and cultural impact to the community, but not dramatically improving the finances of the facility itself.

It is projected that youth sport and adult groups will each rent approximately 12 hours of ice time each week. Higher demand would benefit arena finances. Ice rates are recommended to be slightly lower than Port Alberni, but higher than other smaller Island communities.

The arena public use schedule recommended is aggressive to provide the entire community opportunities to skate. From a business case approach, this also assists in developing ice sports and activities on the West Coast.

OPERATING BUDGET

Recreation Excellence projects that costs can be kept manageable through the Tla-o-qui-aht First Nation. This, and higher ice rates to a lesser degree, can keep the operating deficit lower than some island communities and in the range of cost-recovery that is more typical of more utilized community ice rinks.

Annual Operating Expenditures	\$346,761
Annual Operating Revenue	\$121,791
Annual Operating Net Deficit	\$224,970
Capital Maintenance Plan – Annual Commitment	\$ 43,663
Capital Fund – Annual Commitment	\$ 75,000
TOTAL TAX SUPPORTED COST ANNUALLY	\$343,633

FUTURE AQUATIC CENTRE

The design and recommendations for the ice rink – Phase One of a Multi Plex – take into consideration the addition of an aquatic centre. There will be many synergies in adding an aquatic and fitness component as Phase Two.

The Facility, Capital Costs and Comparisons and Funding

THE FACILITY

Location

The Airport land on ACRD property has been designated as the facility location, which is centrally located for the stakeholder populations, sitting 25 kilometres from central Ucluelet and 19 kilometres from central Tofino. The building site is now on the airport building side of the property, across the runway from the previously proposed site.

The location is seen as acceptable to all the communities. Although not ideal to either Ucluelet or Tofino, however, it appears those we spoke to understood that the inclusion of the entire region is a must to make the venture a success. There is some local feeling that the proposed facility location suffers from being in neither Tofino nor Ucluelet. This is true, and it will affect use for public programming, but, the distance from Tofino or Ucluelet and all the areas in between are within typical commuting expectations for ice rinks.

With the exception of Esowista and Ty-histanis, the proposed location is not within walking distance of any residences. However, it is likely only public skaters or spectators would walk, as the distance is significant for anyone dragging a gear-bag.

We are told subsidized public transportation is not in the foreseeable future for the West Coast, but we do not see this as a major negative for rink use. Our experience is that with the exception public skating, few participants at a rink use public transit in any community.

The areas that are seen as within the catchment of this rink include Ucluelet, Tofino, Area C of the Alberni-Clayoquot Regional District, and Tla-o-qui-aht, Ahousaht, Hesquiaht, Toquaht, Ucluelet (Yuululitaht) First Nations. One North Island community tells us that one-third of their minor hockey members arrive via a 20-minute boat ride, although a shorter commute as compared to Ahousaht it does speak to the potential for great efforts to be made to play hockey. A significant number of adults and some families currently commute to Port Alberni to play hockey one, two, or more times a week. This also speaks to the distances in this case being manageable.

Building Construction

Recreation Excellence considered four construction options for an ice arena as Phase One of a Multi Plex.

1. Prefabricated Refrigerated Panel wall construction
2. Soft Cover – specifically by Sprung Structure
3. Traditional wood and/or concrete construction
4. Metal Shell

The majority of quality ice rinks and community swimming pools built in Canada today include the use of prefabricated refrigerated panel wall construction. We received a list from a wall panel group listing 50 recreation facilities in Canada with their products; they boast high insulation values and durability. Because they are prefabricated, the shell builds relatively quickly. Metal panels are used to “sandwich” insulation and then are erected on site. The installation process creates seamless wall structure to prevent heat and air transfer. Insulated panel technology has long been used extensively for construction of buildings and coolers for refrigeration purposes. Over the last twenty years the technology has been adapted for use in swimming pool and arena construction.

Sprung Structure soft cover buildings have been used in five ice rinks in Canada in the last four years. They claim high insulation value, long life span with affordable mid-life costs, no separate roof to require major rebuilding, air tight construction and a lower original cost of construction. The construction process for the building shell is very quick.

Sprung has been in business since 1887 and has built 12,000 structures in more than 100 countries worldwide. They are now in the recreation and arena field, with several operating in Canada and as such should be carefully considered as a viable choice for good performance and best economy.

The Facility, Capital Costs and Comparisons and Funding cont.

With so few Sprung Structure arenas built, recommending Sprung Structures over the industry standard prefabricated insulated panel construction is a difficult decision, but one that must be considered.

Traditional concrete and wood construction has gone somewhat by the wayside, largely replaced by refrigerated panels. Traditional community rinks lack insulation, require significant upkeep and are not airtight. The construction period is considerably longer and therefore more costs are incurred.

There is a current project in Hazelton that will utilize mostly wood in the construction of a rink and community centre. The architectural firm cites government programs that stipulate wood construction is preferred for grant consideration as a factor in the choice. Wood could blend well for any traditional First Nations look to the facility – either with a wood building or with a wood front. Without examples of completed or even fully specified wood-based projects, a cost comparison is not attempted; it is likely the end cost would be higher, as compared to either pre-fabricated methods noted above.

We added consideration of metal shell buildings to the project only because there are so many in existence. One of the very few single sheets built in B.C. in the last few years (Iskut First Nation, north of Dease Lake) was based on an imported, used metal shell. Using a metal shell saves on initial construction costs and time. We were told the Iskut rink was built for only \$3.8 million but the construction and the equipment as originally installed was not able to maintain proper ice, even in northern winter conditions, until modifications were made. The rust factor (therefore life expectancy), the lack of insulation/energy efficiency, the inability to control moisture and provide consistent ice quality, among other factors, were ample reason to remove metal shell buildings from major consideration.

It is recommended that, should a Sprung Structure be chosen, that the rest of the design is planned by consultants with extensive arena experience, whether part of the Sprung team or not. The goal is to consider different designs to reflect West Coast needs and lifestyles, as would happen if an alternate building type were to be chosen.

A wood building could be considered only if it led to enough additional capital grant dollars to compensate for the cost, and if it was considered a better cultural fit. The energy efficiency of a wood building would also need to be further assessed in order to be considered.

CAPITAL COST – COMPARISONS

There have been few basic single-sheet, stand-alone user rinks built in British Columbia recently; most communities are now building either multi-pads or stadium-style facilities. There are several new rinks built or being built (Quesnel and UBC which are larger, and Cloverdale which will be a twin pad), while there have also been less expensive arenas built that we could use to compare (Iskut First Nations, Leroy Saskatchewan), but we strongly advise against a metal structure such as these due to energy efficiency and lifecycle costs.

The prime reasons to review new arena construction for this report are:

1. To compare costs for various construction types for the West Coast
2. To determine a range of anticipated capital expense for the project

The examples below are not conclusive, as they are not the true comparisons one would get with a tendered project. They do show significant capital savings in a Sprung Structure building.

To arrive at the costs listed below, we have removed any fixtures, furniture and equipment if supplied, land acquisition costs, or other “soft costs” listed in the provided project budgets. Walking tracks in the Cayuga and Dunnville rinks were priced separately and so were easily removed from the equation. Differences remain among the facilities in the scale of the seating and public areas, which we indicate in the comparisons below.

The Facility, Capital Costs and Comparisons and Funding cont.

Ontario

We have found three facilities built in southern Ontario, between 2011 and 2013, of similar size and scale. Two are of the Prefabricated Insulated Panel type, and one is a Sprung Structure. Each was professionally developed by local governments and all three seem to be perceived as having good value by the recreation industry in general and by the local community.

The Cayuga and Collingwood arenas are similar in scale and features. The Dunnville arena is a larger building, making the \$1.75 million extra it cost over Cayuga a similar value.

When compared “apples to apples”, there appears to be more than a million-dollar price advantage with the Collingwood Arena over the other two, which seems to be largely in the building envelope type – the Sprung Structure.

The operator of the Collingwood arena is extremely happy with the performance of the building, being able to keep good quality ice in the summer for instance. He also personally feels that the utility bills are lower than anticipated.

Cayuga: opened 2011; \$9.4 million (adjusted for inflation – \$10.56 million)

- Prefabricated insulated panels with conventional construction for entry and lobby areas
- Seating 450
- Six dressing rooms plus one ancillary
- Lobby space and offices on main
- Room for 150 plus kitchen above
- Significant club storage space
- Security Cameras (\$60,000)
- Elevator
- Some heat recovery; goal to achieve LEEDS Silver level without certification

Dunnville: opened 2011; \$10.9 million (adjusted for inflation: \$12.3 million)

- Prefabricated insulated panels with conventional construction for entry and lobby areas
- Seating 1,044
- Six dressing rooms plus one ancillary
- Lobby space, community room, kitchen and offices on main
- Significant club storage space
- Security Cameras (\$60,000)
- Elevator
- Some heat recovery; goal to achieve LEEDS Silver level without certification

Collingwood: opened 2013; \$8.4 m (adjusted for inflation: \$9.03 million)

- Sprung Structure
- Seating for 400
- Six dressing rooms and women’s plus referees’ rooms
- Significant lobby on main level
- Mezzanine level with canteen and large viewing/meeting room
- Elevator
- Site prep required was minimal, as facility was built on existing baseball diamond

British Columbia

In British Columbia, we are comparing four ice rinks, either built or proposed as concepts. The cost comparisons are more speculative as compared to the Ontario samples; the VVI proposal, although detailed, is dated and the two Vic Davies Architect examples are purely order of magnitude estimates as no engineering specifications or cost quantifying was done. The Shawnigan Lake example is reliable as it is a recent, completed project.

The Facility, Capital Costs and Comparisons and Funding cont.

The facilities reviewed are not equal in features or in overall size. They all would be generally serviceable to the community, although the small Vic Davies Architect facility only offers four dressing rooms. The Shawnigan Lake Sprung facility cost did not account for the relatively expensive construction location of the West Coast in this case, while the others did account for location in the estimate.

As in Collingwood, Ontario, the operator of the Sprung Systems facility in Shawnigan Lake is more than satisfied with the facility. Again, it appears to offer savings over the other facilities, all of which would be prefabricated insulated panel structures.

Shawnigan Lake: opened 2015; Construction and Engineering only, \$8.1 million (adjusted for inflation: \$8.6 million) not adjusted for West Coast Location. Without mezzanine finishing in 2017 costs: \$8.05 million

- Sprung Structure
- Seating for 400
- Six dressing rooms plus referees' room, including one upstairs
- Significant lobby, office, skate shop, concession space on main
- Mezzanine level: two large change rooms, three offices a conference room, and an upstairs lounge completion from shell to finished areas @ \$550,000.
- Elevator
- Site prep included, but was minimal
- Includes some heat recovery

VVI: concept 2012; Construction and Engineering only, \$10.35 million (adjusted for inflation: \$ 11.4 million)

- Priced for West Coast location construction
- Prefabricated Insulated Panel Construction
- No spectator seating at arena level; approximately 150 on second level
- Four dressing rooms plus three "flex" smaller rooms (referee, female)
- Small entry lobby on main level
- Mezzanine level with 3,000 square feet designated "fitness", plus space for future development
- Elevator
- Five small offices plus reception, but lacking required storage and skate shop; in all slightly short on space.
- Site prep allowance removed from costing
- Allowance for West Coast construction (in addition to costs listed) could be lower than in other facilities due to quick erection of Sprung Structure.

VDA Design: smaller, concept 2014; Construction and Engineering only, order of magnitude estimate \$9 to \$10 million, considering location

- Prefabricated insulated panels with conventional construction for entry and lobby areas
- Seating 200
- Four dressing rooms
- Lobby space, meeting room, concession
- Minimal storage space

VDA Design: revised from 2008 concept in 2016; Construction and Engineering only, order of magnitude estimate \$10 to \$11.4 million considering location

- Prefabricated insulated panels with conventional construction for entry and lobby areas
- Seating 225
- Four standard dressing rooms, two flex; two referees'
- Small entry and viewing lobby space, skate rental shop
- Sufficient storage and club areas

The Facility, Capital Costs and Comparisons and Funding cont.

ESTIMATED CONSTRUCTION COST

We have held the belief that construction of recreation facilities tends to be slightly lower in cost in southern Ontario as compared to British Columbia. The two sets of prices in our comparisons seem to confirm this understanding. Therefore, we have based our construction estimates on the B.C. examples.

The capital cost of building construction, including architectural and engineering but not including other soft costs, is estimated to be, at the low end, based on the Shownigan Lake facility without the mezzanine finishing, but with costs added to allow for the West Coast construction location. At the high end, a Prefabricated Insulated Panel building, such as the VVI or larger of the VDA style buildings, estimated to cost between \$10 and \$11.4 million, with consideration for location already determined. Generally we would roughly estimate the additional cost of construction on the West Coast to be 10% of the budget, but with the Sprung Structure, we have adjusted the estimate to 7% due to the quick erection of the structure.

CONSTRUCTION COST	SPRUNG STRUCTURE	PREFABRICATED INSULATED PANEL
Construction with Engineering and Architectural – 2107 \$	\$8.05 million	\$10 to \$11.4 million
Allowance for West Coast Construction 7%	\$563,500	Included
ESTIMATED COST	\$8,613,500	\$10 TO \$11.4 MILLION

Additional Costs of Construction

When referring to the capital “cost” of a new facility, what specific items are included? In determining the dollars required to fund the Multi Plex, the full capital cost includes more than strictly the cost of constructing the building itself. Additional expenses referred to as Soft Costs are incurred prior, as part of the construction phase, and post construction. In short, Capital Project Costs includes all money spent to plan, construct and open the facility and to bring the operation up to speed.

Soft Costs of the pre-construction and construction phases that should be part of any proposal include engineering and architectural design fees, inspection fees, permits and inspections, any loan interest or construction insurance, a reasonable contingency and an allowance for profit.

Other soft costs often appear outside of the construction proposal, but are still part of the capital project.

- Soil testing and environmental assessments may be part of the construction budget as well
- Insurance during construction that the owner may require
- Interim financing by the owner, especially if grants are released at a slower rate than partial construction payments are required. We have roughly estimated financing costs to be in the range of \$100,000

Preliminary Site Servicing costs can vary greatly depending on location; one facility we looked at was built on a soccer pitch, a site already leveled and packed, with all services close at hand. The site for the West Coast Multi Plex is more complex. The area for the Multi Plex building, parking and even the road to the entrance all need to be scraped down and refilled to become a solid platform; services to the location are also somewhat more complex.

McGill & Associates Engineering Ltd of Port Alberni have prepared a conceptual site servicing plan for the proposed Multi Plex location. Site servicing costs may appear in the construction proposal, but often is not because costs specific to the location may not be known. In this case, the ACRD has commissioned a site servicing plan and budget in advance.

The Facility, Capital Costs and Comparisons and Funding cont.

Notes

MCGILL & ASSOCIATES ENGINEERING PRELIMINARY SITE SERVICING COST NOVEMBER 2016 ESTIMATES	
Drain/Sewer/Water	\$ 299,750
Hydro/Tel/Street Lighting	\$122,000
Access Road Upgrade	\$79,300
(Gravel) Parking Lot	\$431,500
Building Site Prep	\$ 346,000
SUBTOTAL	\$1,278,550
Contingency (10%)	\$127,855
Environmental Consulting	\$7,500
Engineering (15%)	\$191,783
TOTAL ESTIMATED COST	\$1,605,688

Start Up-Costs not associated with regular operations for the period from prior to construction through until well after the physical opening of the building are accounted for in the capital budget. Recreation Excellence has developed a reasonable and likely approximate budget for the West Coast Multi Plex start up.

OWNER'S START-UP – WEST COAST MULTI PLEX – RECREATION EXCELLENCE ESTIMATES	
Local Government Initial organizational time	\$10,000
Owners Representative/Project Manager	\$50,000
Systems Development Specialist	\$25,000
Building Commissioning	\$6,000
Furniture, Fixtures and Equipment	\$309,430
Operator Training/Certification Through Year Two	\$21,600
Small Finishing/Carpentry	\$10,000
Opening Events	\$5,000
START UP TOTAL COST	\$437,030

Delays in Opening

Unexpected last minute delays in opening, a time when staff are in place and the building generally being operated, but not fully able to start services, can add unbudgeted costs. We have not budgeted for these as we assume that taxation would have begun in such a case and ongoing savings in some operations areas would offset the revenue not collected during such a delay. It is also assumed that, if the time of year the facility is ready to start does not match the ice season, adjustments would need to be made in the initial operational plan to ensure that costs do not exceed the budgeted deficit.

Full Capital Cost

Without detailed design and related quantity estimates, an accurate capital cost of the facility cannot be fully known at this point. The greatest unknown is the cost of construction. In many cases, such as design-build or construction management approaches, costs are determined as the construction evolves. Even in the case of a pre-priced project change orders will always move the cost upwards; the hope is that contingency funds cover this in the estimated costs.

The next phase of this project will engage an architectural and engineering team to refine the conceptual plans and prepare detailed design drawings and building estimates. These will satisfy the requirements of the various grant agencies and provide accurate costs for the West Coast Communities.

The Facility, Capital Costs and Comparisons and Funding cont.

Estimated costs for the two types of building construction are as follows:

COSTS	RANGE OF ESTIMATES	
	Sprung	Prefabricated Insulated Panel
Construction Proposal Including Builder's Soft Costs	\$8,613,500	\$ 10,000,000 to \$11,400,000
Site Servicing	\$1,605,688	\$1,605,688
Owners Insurance and Financing	\$ 100,000	\$ 100,000
Owner Start Up Costs	\$ 437,030	\$ 437,030
TOTAL CAPITAL COST	\$10,756,218	\$12,142,718 TO \$13,542,718

CAPITAL FUNDING

The referendum passed to support the Multi Plex specifically addressed operational costs only. Capital funding for the entire project is intended to be through grant acquisition and fundraising.

Grants

Local governments depend on various Federal and Provincial grants to address infrastructure needs; both Ucluelet and Tofino have major projects as ongoing priorities that they will need to partner with the higher levels of government to fund. It must be considered that any one grant received often reduces the potential for other funds under the same program.

The Tla-o-qui-aht First Nation similarly has economic priorities that compete for priority in grant applications such as housing, water and other infrastructure. One program, the Western Economic Diversification Canada, does seem to hold some promise for a limited grant for a recreation facility.

FUNDRAISING

The West Coast Multi Plex Society is actively raising money in the community and will take the fundraising to higher levels as the project evolves. To reach the goal, it's felt there is a potential to source a large portion of the capital cost of the facility through major donations, both corporate and individual.

Heart of the Hazeltons

Public recreation facilities typically do have a local fundraising component. One that is ongoing, but already has achieved success, is the Heart of the Hazeltons project that has raised \$4 million locally, which aided in securing major grant money from a variety of government programs.

The Hazelton arena was long known to need replacing and it was recognized that there needed to be more facilities – a community centre gym and fitness component — to add to the complex. The situation became urgent when the arena was immediately and permanently condemned in the midst of a hockey game.

The local fundraising campaign grew immediately into the need. As local fundraising continued, the Hazeltons were able to secure grants with applications, starting with \$6 million federally from the Gas Tax Fund. The Building Canada Fund – Major Infrastructure was tapped for \$1,875,788, to bring federal funding up to 50 per cent of the total \$15,751,576 identified as needed. This is the allowable maximum of federal funding on any project to which the Build Canada Fund contributes. The Province granted an additional \$4 million dollars.

The Heart of the Hazeltons is spearheaded by one well-known physician, and makes use of high profile local athletes as promoters. They engaged a professional fundraiser to shape the campaign and to assist in “The Ask” for major contributions. Their consultant stresses that contributions are about building the community more than building a rink, and that relationships built through initial donations will continue after the opening of the facility. They have achieved several large donations; some of the donors silent.

Refrigeration Systems

Recreation Excellence was asked to review and consider recommending the type of refrigeration system/ice plant for the proposed facility. We considered the following refrigeration system options:

1. Ammonia
 - a) Typical arena plant
 - b) With additional heat recovery systems
 - c) With a plant under 25kW (including heat recovery systems)
2. Carbon Dioxide
3. Kube Solutions (Formerly Ice Kube) and Ice 3
4. HCFCs (Freon)

We recommend:

- An ammonia refrigerant system, including all available heat recovery systems, be installed at the time of construction. If specifying the ammonia system to be with compressors under the regulatory threshold of 25kW has proven effective by the time of construction, this would be the preferred option.

Ammonia

Ammonia is used as the refrigerant in most ice arenas. Through being transferred through gas and liquid stages by compression the ammonia is cooled so it is able to extract heat from another liquid – brine. The brine is circulated in lines imbedded in the concrete ice pad, cooling the ice pad to allow ice to be made and maintained. The process is energy intensive, the main reason electricity is a major expense at arenas. There are also safety issues with ammonia, with both toxic escapes and explosions being possible. Hence, significant care and expertise is required to operate an ice plant.

Carbon Dioxide (CO₂)

Using CO₂ as the refrigerant does not carry the risks of ammonia in the case of a release. As such, it does not fall under the regulations of the Safety Authority. It is more expensive to install, although not to operate. There are at least 25 such facilities in Europe, now under the licence of major refrigeration manufacturer Cimco, which is just coming to Canada. Trends move quickly and there could be a move toward Carbon Dioxide (CO₂) as the refrigerant. Even though it's not likely, it's something to keep in mind.

Kube Solutions (formerly Ice Kube) and Ice3

Kube and Ice3 use heat pumps to cool the ice slab. They currently both seem stronger on the east coast (in both the USA and Canada). The history with this technology in British Columbia has been negative, so we would not recommend considering this unless some of the recent installations prove very effective.

HCFC as Refrigerant

Should the ice plant make use of an alternative refrigeration system, specifically using HCFC (hydro chlorofluorocarbons, commonly referred to brand specific Freon), the above Act would not apply. Freon was a common choice years ago; the National Arena Census from the Canadian Recreation Facilities Council reported in 2005 that 25 per cent of Canadian ice rinks were refrigerated with Freon.

However, HCFCs have faced increasing regulation due to environmental concerns with ozone depletion with any release of the gases for HFCFs, and greenhouse gas effect for all of them.

Although still legal, it will soon become illegal to build or rebuild such systems, and eventually to operate them at all (2016 Amendment to the 1987 Montreal Protocol). It is common consensus that it would be unwise to consider any Freon-based option at this point.

NEED FOR ENERGY EFFICIENCY

Energy savings features, and therefore greener options, are worthwhile for the Multi Plex even though they are more costly at the outset. Although the efficiencies described could, in part, not be installed initially with the plan of accessing future grant dollars to make improvements, the savings likely warrant proceeding as much as possible at the start. Considering programs with payback in utility savings in less than 10 years, and assuming grants available at zero per cent at construction

Refrigeration Systems cont.

Notes

and 50 per cent of the cost of input with a later funding application, one would need to anticipate making the upgrades in the first five years of operation to make waiting financially worthwhile. For this reason, we recommended green/energy saving options are included in initial capital projections, even though the implementation could be strategically considered when the final design is at hand.

Recreation facilities today are continually improving utility consumption to lower costs. In community arenas surveyed, energy expenses were up to and beyond 20 per cent of total operational costs — the next biggest expense after labour costs.

Electricity is the greatest energy use in arenas, specifically the cost of cooling the ice slab. As natural gas is not available on the West Coast, there will be relatively high costs for heating the water for showers, the process of ice maintenance and for heating air in public warm areas.

Heating costs would be much more significant when an aquatic centre is added; the task of maintaining temperature in the pools, heating showers, heating the air throughout the entire building, and due to the process of reducing humidity, by expelling already warmed air.

A significant idea – heat looping with Tla-o-quo-aht Nation's geothermal project – could be an energy boon to the project. Although the distances are significant, with piping estimates at about \$60/metre installed, it's well worth having Accent Refrigeration take a closer look! The concept is to collaborate with other local projects to potentially save more energy and emissions is to join the Multi Plex heat recovery with the Esowista and Ty-histanis communities' geothermal loop and to possibly add the airport into the system. Accent has done a similar project in Port McNeill that is producing significant savings for the local school. In the case of the Multi Plex, heating costs could be saved at the airport. Further, there is the potential to trade savings in energy – flowing to the community during the ice season and, in the future, from the community back to the swimming pool and airport when the ice is out.

We have not budgeted for either the capital cost or the operational potential savings of looping with the geothermal project or extending to the airport.

PLANT CAPACITY AND THE B.C. SAFETY AUTHORITY RISK ASSESSED STATUS

The requirements of operating an ammonia ice plant can be onerous. To avoid restrictive staffing safety requirements, the option of specifying compressors and plant sufficiently undersized that they would avoid regulation, could be a significant advantage. Accent Refrigeration, based in B.C., has specified a similarly sized ice surface (albeit a curling rink) in Chilliwack. If this proves problem-free, and hopefully other examples also follow, it would be recommended to specify a plant with compressors under 25kW power.

Should the final design of the ice rink include a standard ammonia refrigeration system of greater than 25kW per compressor, as almost all ice rinks currently are, operation will be governed by the B.C. Safety Authority's Power Engineers, Boiler, Pressure Vessel and Refrigeration Safety Regulation. This act determines the staffing and training levels required to monitor the facility at any time that the plant is in "operation".

Without "Risk Assessed" status for ammonia plants greater than 25kW, it is technically required that the plant be monitored by fully qualified staff 24/7 throughout the ice season. Although 24-hour staffing is often not followed in B.C., most now meet the qualification requirements of staff.

"Risk Assessed" at an ice rink is a designated status bestowed by the B.C. Safety Authority, pertaining to design/construction, plus an operating plan providing a higher level of safety in the operation and monitoring of the ice plant. With "Risk Assessed" designation the level of supervision of a plant is lessened. The "Risk Assessed Plan" could specify varying levels of staffing, however, the following assumes that the common level of staffing (also the least level) is agreed upon.

It is recommended and assumed that the design, if greater than 25kW, would meet the requirements of Risk Assessment and that required operational plans be in place prior to completion of the plant to allow for immediate inspection and certification.

Refrigeration Systems cont.

Notes

Assuming the plant compressors are the industry-typical minimum 25kW each, with “Risk Assessed” status, staffing requirements will be as follows during the ice season:

- A “Chief Engineer” is required to be certified through the Safety Authority with the Power Engineer Refrigeration Endorsement. This would likely be the Lead position.
- Additional operators certified as Power Engineers, including Interim Certified, or Ice Facility Operators designation to ensure at least one shift each operating day is attended by someone with one of the above certifications.
- Interim Certified means a person who is working toward Fifth Class Engineer and is accepted by the Safety Authority as such. It is a one-year designation, although application can be made to renew. It is possible that the fulltime position would be Interim Certified, but there must be a Lead Engineer who does work at the facility.
- Other operators with at least a certification of “Refrigeration Safety Awareness” to attend the facility at all times it is in use, but not other hours.
- The plant must be monitored on a minimal basis on any day when running but the rink is not in use.

The cost of achieving and maintaining “Risk Assessed” status has increased in recent years — there are ongoing documentation and inspection processes required — but the costs and efforts are still minor compared to the gains in staffing efficiencies that are allowed, but they are budget considerations.

In practical terms, it is recommended that at least two staff become certified Fifth Class Power Engineers, as one leaving permanently without a backup would cause significant issues with the Safety Authority.

If an aquatic centre was added at a later date, it could be a significant advantage that the facility be designed to be certified as two separate units (pool, administration and lobby separate from the ice rink and rink change rooms) so it wouldn't require certified staff in any way during ice season when the pool is in use, but the rink is not.

Recruitment, training and certification of staff is a significant and ongoing task. An allowance has been made in the Start Up budget to account for Risk Assessment and for training new operators over the first 18 months. Should this requirement be avoided due to the plant design, there would be some savings both in Start Up and ongoing.

Management and Operating Models

Most community recreation facilities in British Columbia are managed and operated by the government that owns them. There are a number, however, especially when owned by Regional Districts, where a community within that District that makes up the majority of the taxation base (a sub-region) operates the facility on contract from the Regional District. Still other times, a non-governmental operator, either a Not-for-Profit or a private contractor, assumes some, or all, of the responsibility to operate the facility.

In the case of the West Coast Multi Plex, there is not one clear community that would naturally take responsibility for operations. This section identifies the stakeholders, considers what role others might take on in the operations, and then makes recommendations on arrangements that could work best between the Alberni-Clayoquot Regional District (the owner) and those other parties.

Stakeholders identified as potentially taking a role in managing, operating, or programming at the West Coast Multi Plex include the groups listed below.

- Alberni-Clayoquot Regional District (ACRD)
- Tla-O-Qui-Aht First Nation
- District of Ucluelet
- District of Tofino
- West Coast Multi Plex Society
- Third Party Contractors

At time of this report, the most likely option for management and operation – and one that is recommended – is that the ACRD would oversee, but the Tla-o-qui-aht First Nation be considered as the first option as operator. Program administration and delivery could go through either Ucluelet or Tofino, or both, but the Tla-o-qui-aht First Nation may also do this, and may be required to. Should Tla-o-qui-aht both operate and program the facility, they would also naturally be the overall managers.

Within the discussion below, the management and operational functions are discussed in the following areas:

- Oversight (1. Taxation; 2. Board)
- Management
- Ice Facility Operations
- Programs/Facility Rentals
- Rental/Sport Groups
- Advisory/User Group Committee

OVERSIGHT

1. Taxation Authority

The ACRD will set and administer taxation for the defined areas: The District of Tofino, the Village of Ucluelet, and Area C of the ACRD. Residents of Ucluelet and Tofino will pay through their regular annual property taxes to their respective local governments, who then remit to the ACRD. Area C residents will pay for this facility through their tax assessment, and will pay directly to the ACRD as part of that assessment.

The ACRD, as the taxation authority, would maintain control of the overall capital and operating budgets and the protection of the asset through a proper maintenance program. The ACRD would also want to be assured that the facility is being well promoted and well used.

Depending on the operating structure, the ACRD could be indemnified for operating/program mishaps of outside service providers, and would want assurances that prudent management is in practice. This would involve a reporting timeline and structure to include operating procedures, setting and meeting goals, quality and sufficient programming, preventative maintenance, completion of capital projects, and more.

Management and Operating Models cont.

2. Board

A Board is not a required function, but is used in the case where a Not-for-Profit operates or takes the lead in a facility. A potential Board would likely consist of non-voting administrative and possibly political representatives from the ACRD, plus elected, voting members representing the West Coast Multi Plex society. First Nations would likely hold a Board seat; if the Tla-o-qui-aht First Nation was active in providing management and significant staff they would hold an additional non-voting seat.

A Board would utilize the services of the ACRD representative as well as the facility staff to assist in developing budget, policy, HR matters and the like. The Board would report/submit to the ACRD, who would maintain decision making on financial matters including major maintenance and capital budgets.

A Board, except as required as in the case of a Society, may compete for energy and resources against a User Group or Advisory Group Committee. It may be wisest to concentrate community energy within the sport groups within their own organizations. As such, a Board is not a recommended function in this case.

MANAGEMENT

The arena can be considered one function provided by one group, or responsibilities could be divided among two or more groups to create a team that might provide a stronger overall delivery, and, hopefully, without significant extra organization or confusion.

As the ACRD will be overseeing the project, it is likely that the ACRD also provide the management, unless one single group comes forward to provide all facets of operation. Should one group come forward to take on all aspects of service delivery (ice operations, programs, rental use management, etc.), then they would also be the managing body. The ACRD, the Tla-o-qui-aht First Nation, either Tofino or Ucluelet, a contract operator, or the West Coast Multi Plex Society could each be considered, but only the ACRD or Tla-o-qui-aht are recommended.

ICE/FACILITY OPERATIONS

For the purpose of this report, Ice Facility Operations or Operators, refers to those staff who maintain the plant and building systems and equipment, and the ice itself.

None of the local entities currently have the systems, the procedures, or the skills in place specific to ice rink operations. This means that there will be significant developmental work to be done prior to beginning operations and over the first year or two. It is recommended that contract assistance is sought to identify and develop necessary procedures and record keeping, install the initial ice, train staff, and ensure “Risk Assessment”, if required, happens quickly. The cost for this additional initial training is allowed for in the Start Up budget.

Ice operations, would likely be provided by the ACRD or potentially the Tla-o-qui-aht First Nation, both of whom have “Works” departments. We recommend the Tla-o-qui-aht First Nations as the first option.

PROGRAMS/FACILITY RENTALS

The “Program” function includes visioning, development, marketing and delivery of recreational services, or programs. Along with Program management would come working with rental groups.

There is significant sophistication involved in handling bookings, registration, possibly memberships, drop-in attendance; money and sensitive data are involved. It is recommended the manager enlist help with policy and procedure regarding any processes of administering programs and rentals in which they may be lacking.

Program delivery, at least the front-line instruction, could be contracted to some degree. It fits well with the seasonal, part time nature of the function as well as the fact that programs often become more or less than anticipated due to registration or attendance. This is a model that Ucluelet and Tofino use to some degree in recreation, and the ACRD in its landfill operation. Supervision of public skates could be hired as entry level positions, or be part of a contract.

Management and Operating Models cont.

Notes

Ongoing informal supervision of program staff can be assisted by rink operators, who also often serve as the cash collectors for drop-in hockey programs and sessions with only the occasional skate rental request. Although it is an inconsistency to have the operating staff also doing this program function, these tasks are typically part of any ice person's job duties, so it is hoped the parties would simply work together.

RENTAL/SPORT GROUPS

Sport and other rental groups are independent of the ice rink operation from a legal and administrative standpoint, but from a practical sense are partners in ensuring that the entire public is well served. User Group policy in relation to preferred rates for youth sport for instance, should involve the mandates of inclusivity and developing the sport involved. The arena has a responsibility, too, in supporting the rental groups; Minor Hockey among other groups, are essential to the success of the facility, and all parties must take responsibility for shared success.

ADVISORY/USER GROUP COMMITTEE

User Group Committees are usually made up of one representative from every renter. Advisory groups are often honed down to key groups plus selected members of the public with interest in drop-in programs, public skate, etc.

We recommend there be one group – a combination User Group/Advisory Committee. Groups need to buy into the philosophy that all use is highly subsidized and therefore participate in the responsibility to bring full value to the community (as cited in the “Benefits” section of this report). Understanding the financial impact of subsidies on the community tends to move groups to ask how they can help.

POTENTIAL PARTICIPATION IN MANAGING, OPERATING AND PROGRAM DELIVERY BY EACH STAKEHOLDER

The following section considers areas of strength and weakness of each, and recommendations on if, or how, each might be considered.

ALBERNI-CLAYOQUOT REGIONAL DISTRICT (ACRD)

The most straightforward operating model for the Multi Plex would be for ACRD to operate the facility directly in all areas. Russell Dyson, CAO of the District indicates that this is an option, and that if no other viable option were to be determined, it would then become the option. It is not the preferred option of the ACRD however, as strength is seen as being built through as much local involvement and control as possible, and economies may be improved by enlisting contract operations.

Oversight: Protecting the asset is of high importance to the ACRD as owner of the proposed facility. With an Airport Manager stationed 300 metres away, there is a natural fit in assuming an oversight role. The ACRD will require reporting on budgetary figures, at appropriate times, in order to evaluate and approve each year's allocation of tax dollars.

Management: The ACRD could manage the Multi Plex directly, again through the Airport Manager, whether they also employ the Ice/Facility Operators, or through one or more partners (likely Tla-o-qui-aht as Operators, or a third-party contractor) and yet another partner providing rental services and/or programs.

Should the ACRD manage and staff the Arena it will set precedent for future facility expansion and operations with respect to the use of CUPE staff. Given that the ACRD falls under the same union as the City of Port Alberni, CUPE Local 118, it will be very difficult if not impossible to switch to non-union or contract staff once the initial ACRD staff is implemented. This is a significant consideration not just due to the lack of flexibility in the operation of the ice facility, but also the relatively high rates for aquatic staff that would eventually befall the operation. The same would not necessarily follow if the ACRD were to manage only, as the function would be handled by an exempt staff. Any other impact of the ACRD's Collective Agreement should be

Management and Operating Models cont.

clarified prior to moving forward.

Ice/Facility Operations: The ACRD is a professional organization with the capacity to incorporate this function.

With the potential of an aquatic centre in the future, starting the facility with a locked-in union staff is less preferred as it would close the door on more flexible and economical options in the future.

The ACRD believes it could provide Operators, employed under their Collective Agreement but separate in terms of “bumping rights”, from the larger group of staff in Port Alberni. The “bumping rights” question is an important distinction, meaning that the ACRD would have some ability to develop and maintain staff on the West Coast despite the seasonal aspect of employment at this point.

The staff complement, from the lead position to seasonal staff, could meld with the current Airport staff, bringing a larger and therefore more flexible complement, perhaps also giving more flexibility to day-time ice rental options.

As the ACRD does not currently employ rink operators or people specifically with those skills there would be significant training requirements. Initially they would need to reach outside to find qualified/certified operators with the necessary technical experience. The ACRD would likely find that process, under its Collective Agreement, much more expensive as compared to other options.

Programs/Facility Rentals: The ACRD has a skilled, stable clerical workforce stationed in Port Alberni who could administer ice bookings, but it has no location on the West Coast to do so. It is not ideal to have the public face of facility use stationed in Port Alberni.

The addition of an aquatic facility, would include programming and reception staff on site at the Multi Plex. However, it would be tremendously inefficient if bookings needed to be handled on-location by office staff on duty for the rink-only. Likely, should the ACRD handle bookings and registration, there would be a staff designated in Port Alberni to administer those functions and be a resource to rink employees and contract instructors, not an ideal situation. Therefore, should the responsibility to employ and supervise the skate instruction, hockey program leadership, or public skate staff, the most likely option for the ACRD would be to contract a local person with the skills to do so.

It is also possible that a Lead Operator could also handle the organization of user groups and contract instructors – an all-round arena lead person. This is also a strong option for the ACRD; the weakness is in retaining such a staff person through the summer “dark” season at the arena.

TLA-O-QUI-QHT FIRST NATION

Management: Tla-o-qui-aht is a viable and realistic option to manage and operate the Multi Plex arena. They already have the human resources and accounting functions to conduct the administration of the Multi Plex. Tla-o-qui-aht sees advantages in creating employment within their organization, so are not averse to taking on more responsibility in the form of administration and operation.

The Tla-o-qui-aht First Nation should be considered for management responsibility in concert with providing ice facility operators.

Ice/Facility Operations: As no local organizations currently have ice operators, Tla-o-qui-aht could also have an advantage with greater access to training funding as compared to others. Tla-o-qui-aht’s Water operators handle technical equipment that requires specific certification – an operation with parallels ice rink operation. It is also possible shifts could be integrated with Water Department functions, enlarging of efficiencies akin to how the ACRD could share staff with the Airport. The wage structure at Tla-o-qui-aht is more affordable than any of the other local governments.

For the first number of years, a lead staff with arena ice skills would be needed. Perhaps the Tla-o-qui-aht would be the group most comfortable with creating a seasonal contract for a lead/training staff position for the first few seasons and be the ones most able to bring in help when it is needed and employ locals at all other times.

Programs/Facility Rentals: Tla-o-qui-aht sees value in creating employment for entry level staff to work at public programming (public skates, skate rentals). They could be better positioned to

Notes

Management and Operating Models cont.

amalgamate a Programmer position into another job description, as compared to the ACRD, as they have other local departments that are a closer match. Programs such as skate instruction and adult hockey development would likely be outsourced. To operate even the public skates Tla-o-qui-aht would need skilled guidance initially; with training dollars available, they may well be able to contract leader/mentors for these functions at first without additional cost to the facility. Tla-o-qui-aht could purchase the same software as Ucluelet and Tofino for bookings and registration and obtain locally the support it would need to come up to speed on the processes, or handle these functions through current accounting software until the time an aquatic centre is added.

THE DISTRICT OF TOFINO/MUNICIPALITY OF UCLUELET

The question is not whether the local governments have the abilities to develop and provide all or some of the services of Management, Operation and Programs to the facility; within each community's strategic plan, doing so is not a priority or goal. Although providing services to the facility by one community would not change the funding responsibilities to all communities, it would put an administrative strain on that community.

Management and Ice/Facility Operations: We understand that Ucluelet and Tofino each feel they do not currently have the capacity to manage or to develop the team to operate the facility. There could be some synergies in having one or the other take on the manager role for this facility, allowing for an allocation of part of that person's salary to the project. However, to provide management but not staff would simply be adding an extra layer and is not recommended.

If either community did operate, there would be bumping issues within their workforce, and with the need for specifically skilled operators at the rink, create a revolving door of rink training and hiring. It is considered viable for Tofino or Ucluelet to handle ice facility operations only as part of overall control of the facility, which is not likely, nor recommended, at this time.

Programs/Facility Rentals: Although many may see one of the two local governments as the obvious choice to provide at least program management and leadership to the facility, it is not the responsibility of either community to take on ice rink rentals and/or programs.

Importantly, at this time neither community is receptive to take on overall rental and program management of the facility. If one or both together were to re-consider, it would be a service for which they would charge the facility appropriately, something that is obviously required, but is not necessarily seen as sufficient.

There may be more willingness from one or the other of Ucluelet or Tofino to be providers of some public programs at the facilities, being instructional programs first, but less so public skates and certainly less again to manage the program needs or administration and ice rentals. To not include public skating as part and parcel with instructional programs would, however, leave a void that would be difficult to fill. Both communities do have professional staff with the skills to take the lead in the program function; they know the resources in the community to lean on, and have spent years learning the needs. They (will) have the software and skills to handle the process in a professional manner, as they are both moving to Perfect Mind recreation software which is also the registration software the City of Port Alberni selected and installed in 2015.

With the above in mind, Ucluelet or Tofino, or a team effort by the two, could be a strong option to provide Program and Rental management and delivery for a West Coast Multi Plex arena; but it is not currently seen as the most likely option.

Notes

Management and Operating Models cont.

THE WEST COAST MULTI PLEX SOCIETY

Management and Ice/Facility Operations: The Society has not expressed the desire to manage or operate the Multi Plex.

There are examples of local recreation societies managing and operating facilities: Regional District of Bulkley Valley/Nechako with the Smithers Pool; City of Salmon Arm with the Salmon Arm Arena and Aquatic Centre. However, in both cases the facilities are sufficient in scale to employ professionals in the field as the lead. As this facility is not seen as being able to afford a year-round dedicated manager, it would likely leave the Society to be directly involved in management decisions; this would become a major workload for the Society.

Programs/Facility Rentals: It is not clear how the Society would effectively manage facility bookings or immediately respond to inquiries. To manage instructional or other programs, the Society would need to hire a coordinator, which would be a more natural fit overall for one of the local communities or Tla-o-qui-aht.

The Society could recruit volunteers for programs. There will be public skate hosts, drop in hockey supervisors, and possibly assistant skate instructors, some or all of which could be seen as appropriate for volunteer positions and all that mesh well with typical functions of a coordinator of volunteers. This would put the Society in a frontline role in promoting use of the facility on a daily basis and to create, through volunteerism, a level of public service and excitement that is not the norm in ice rinks.

The Society could also function as promoters for special bookings, specifically events, whether in a formal or informal way, as the Board of the Society has, and likely will continue to have, individuals with strong event and/or hosting backgrounds and contacts.

The Society *will* evolve, but not towards operating aspects of the facility. The Society will need to be fundraisers, boosters and networkers to assist operations. The Society will be the catalyst for Phase Two of the Multi Plex. Other responsibilities would interfere with the necessary ongoing functions of local promotion of the facility, and its programs and events and especially of promoting further development.

THIRD PARTY (PRIVATE) CONTRACTOR

Contract Management and/or Operations: Recreation facilities in governances that do not already offer all the functions involved often lend themselves well to outsourcing to private contractors. There are gained efficiencies in not having to build all systems, procedures, policies, etc. from the ground up, let alone creating new management and operational departments.

In the case of this one rink, however, with a limited season of full operation, it is hard to envision a professional contract operator being a competitive option. The cost of managing the contract would be too high as a percentage of overall costs, and the synergies of staffing less accessible as compared to one of the local governments. With this in mind, contracting the operation of the rink-only to a private manager/contractor is not likely a viable option.

It should be understood that a Contract Operator does not equate to privatization. In the case of the Contract Operator, price structure, hours of availability, and the types and emphasis of programs, are prescribed to the Operator, although a good Operator is a valued partner in those decisions.

With a full Multi Plex, a Professional Operator could bring a range of expertise to the table to economically manage and administer all aspects of the facility. There are a number of ice facility operators in the business (Canlan, RG, Recreation Excellence); aquatic operators are more limited, although Recreation Excellence does operate nine aquatic facilities of various sizes.

Programs/Facility Rentals: With neither of the local governments currently willing to provide Program and Facility Rental management, contracting directly to an individual or group to provide program planning and management as well as simple program delivery may be considered. Program delivery by contract would be more feasible if local communities handled the administrative end of bookings, billing and program registration, using their administrative systems and staff.

Management and Operating Models cont.

Notes

ADVISORY/USER GROUP COMMITTEE

An Advisory or a User Group Committee does not have a role to play directly in the facility management or operation, but should be relied on for feedback on how the options chosen are working and should be there to assist, perhaps especially the Society, in working towards a busy and successful West Coast Multi Plex.

SUMMARY

- The ACRD is the owner and will be the overall authority for the Multi Plex.
- It will be according to the will of the ACRD that considerations are made in regard to operational models for the West Coast Multi Plex Arena and what role, if willing and able, other partners would play.
- The ACRD is very clear that they will support and encourage local involvement or complete local provision of the operational services.
- The ACRD could provide management and facility operations as a separate geographical CUPE from its Port Alberni operations, or could engage the Tla-o-qui-aht First Nation to manage and operate the facility. Other options for management and operation are less likely.
- If the ACRD were to operate the facility, it is likely that the arena and an eventual aquatic centre, would remain CUPE operations, with the wage rates that dictates.
- If the Tla-o-qui-aht First Nation was to operate the facility, they would have more flexibility in internal staffing and contract arrangements. The fact that they would be a contractor leads to the ACRD having options in the future.
- Either operator, the ACRD or the Tla-o-qui-aht First Nation would need to hire an experienced ice maintenance person to lead and complement their local staff and other hires.
- Ucluelet and/or Tofino could provide bookings, registrations and possibly programs as a whole. Neither is keen on the administrative function, leaving a gap that may then fall upon the arena, being either ACRD or Tla-o-qui-aht.
- The arrangements that take form when the facility is opened may not turn out to be the very best option as time goes by. For that reason, the structure of the agreements made between the ACRD and the stakeholder parties should allow for appropriate limits to the term of each agreement, avenues to amend, and the ability to give proper notice to terminate.

Staffing

The potential management and operating entities for the West Coast Multi Plex will have their own plan on specifically melding management and staffing with their other operations. Rather than producing a specific staff plan specifying all positions, we have identified and quantified each function. We are recommending on the cost of various functions based on the time commitment each is projected to require.

ADMINISTRATION

Administrative and Management Functions

The staff person with overall responsibility at small community arenas fulfills other duties either at the arena or within the organization and is generally either:

- A recreation or works manager, or
- The lead hand operator or foreperson

The time commitment to administration of the Multi Plex will vary seasonally, making melding this job with other responsibilities all the more important. The efficiencies of offering only the times that will be used, including being closed much of the time during the dry floor season can only be realized if the lead position can efficiently juggle other portfolios or functions.

There is also a management component beyond the lead person, coordinating the various arena departments, responsibility to the ACRD for budgeting, reporting, etc. and decision making on human resources questions.

Over the entire year, we estimate the management function to require about a 25 per cent commitment of an individual – \$25,000

Clerical - Cash Handling, Registration and Deposits

These clerical functions would likely be handled out of the office of the managing organization. The \$15,000 charge back would represent our estimate of five to ten hours per week during the ice season and five hours per week during dry floor and summer seasons, to include:

- Payroll on a bi-weekly basis
- Administering rental contract billing and collection
- Reconciling program registrations
- Handling, reconciling, and depositing of cash several times a week during the ice season and weekly during the dry floor season

Ice Allocation and Program Planning and Supervision

These functions would package nicely into a portion of the job typically defined as Programmer; over the year we would see this as approximately one third of a full time equivalent. It could be combined with some program leadership and hockey instruction, with ice operator duties, or perhaps best as part of larger program organization portfolio of some sort – \$25,000.

Summary - Administrative, Clerical, and Program Management

Administration	\$25,000
Cash Handling, Registration and Deposits	\$15,000
Ice Allocation, Program Planning and Supervision	\$25,000
TOTAL ADMINISTRATIVE AND MANAGEMENT	\$65,000

ICE OPERATIONS, MAINTENANCE AND JANITORIAL

The suggested ice season schedule is for about 60 hours of available ice scheduling per week but, even having reasonable flexibility in timing of shifts and creating several short shifts, will result in 80 to 90 hours of staffing. With either the Tla-o-qui-aht First Nation or the ACRD as operators, combining other job sites and functions with the rink is a must-have efficiency. This also allows a reduction of hours should rental use not meet fully our expectations, without losing staff.

We have allowed for 84 hours of operator staffing during the ice season; 32 hours during the dry floor season, and 24 hours during the dark season. The ice-installation week is allocated 110 hours

Staffing cont.

Notes

and the ice-removal week 50 hours. The wage structure is based on the Tla-o-qui-aht First Nation scale, and is estimated to be \$35 per hour at most including all benefits.

With a ten percent contingency for unplanned overtime and call-ins, the Operator budget is \$108,339. This number will need to be adjusted as the wage structure for operators is understood.

No hours are scheduled or budgeted for special events such as additional tournaments, trade shows and gatherings. The staff costs would be in addition to the schedule here, and be charged back in the rental of these events.

This allocation is significantly lower than our estimates in 2008 as it is for a rink only. It reflects more condensed hours of operation and allows for the operators to perform the janitorial functions as part of their duties in the reduced facility.

Summary – Operators

ACTIVITY	HOURS PER WEEK	WEEKS	TOTAL HOURS
Ice Installation	110	1	110
Ice Season	84	22.5	1890
Ice Removal	50	1	50
Dry Floor Programs	32	13	416
Summer (dark) Season	24	14.5	348
Contingency			281.4
TOTAL ANNUAL OPERATOR HOURS			3095.4
Operator Budget @ \$35 per hour including benefits, plus statutory holidays worked			\$108,339

Alternative Cost – ACRD as Operator

Should the ACRD operate the facility, ice operator costs would be higher. Using the City of Port Alberni as a model for wages, as it shares the same overall union body, ice operators would likely be the same scale. Arena Maintenance Worker are paid \$28.93 to \$31.55 plus benefits. Assuming an average wage of \$30.24, plus a full cost of benefits load of 56% the final cost per hour of ice maintenance staff, if the facility were operated by the ACRD, would be \$47.17. With 3095 hours ice operators per year, the cost would be \$146,005, and increase of \$37,666 over the potential cost of operators with Tla-o-qui-aht First Nation. Further higher costs would likely occur as typically less flexibility around daily scheduling would result in more staffing inefficiencies under a collective agreement.

Program Staff

Staff will be required to receive cash, rent skates and supervise various programs. In this case, as in many arenas, the ice operators are seen as part of the program delivery team. Additional staff will be required for busier sessions and activities deemed to need on-ice supervision.

We have allowed for scheduling one program staff in addition to the operator for a number of specific weekly sessions and two program staff on two of the skates each week. These staffing levels match our projections for attendance and therefore revenue. Should public response be greater, the staffing commitment could be extended to match.

Summary – Program Staff

ACTIVITY	HOURS PER WEEK	WEEKS	TOTAL HOURS
Ice Season	36	22.5	810
Dry Floor Programs	12	13	156
TOTAL ANNUAL OPERATOR HOURS			966
Program staff budget @ \$17 per hour including benefits			\$16,422

Use

The two major ice rental groups, and sources of revenue, will be adult recreational hockey and Minor Hockey. Public programs, both drop-in and registered, will include public skating options, drop-in hockey, “stick and puck” and instructional programs. Regular dry floor activities will include drop-in sport programs and, hopefully, sport rentals. Schools will rent the ice occasionally, as well as potentially some community or family skate parties. In addition to these standard programs at rinks, there is the potential for varied special uses, which we describe below.

ANNUAL GENERAL SCHEDULE

The annual schedule of programs recommended as a reasonable projection and budgeted for is based on community need as indicated by the population base and the information we have gathered specific to this community. Recreation Excellence made many calls to the community to discuss demand for ice use. We also compared use in similar communities and we made statistical comparisons by school enrollment for Minor Hockey potential.

A stand-alone rink can be operated seasonally quite effectively, if there is a continuity of staff despite seasonal employment. There will be employment during the dry floor season, but at a lower level. With this in mind, the proposed strategy is a short ice season, compacting demand into the winter season, then increasing the ice season with demand on a break-even basis.

There will be future economic efficiencies in staffing and energy (heat recovery) with an eventual aquatic centre, allowing for a longer ice-season, as well as staffing dry floor activities more cost effectively. In the meantime, maintaining ice must be considered in terms of the use and revenue each week.

The minimum operating season for an ice rink spans the annual minor hockey season, which would roughly coincide to the high demand season for adult hockey and general recreational interest in skating. We anticipate demand to drop off dramatically in early to mid-March.

When the actual demand in this community is determined, there will be a need to adjust the program plan. This schedule starts by providing basic service, and demonstrates that it can be delivered at the cost shown. Increased demand would allow for increased services and programming.

ICE SEASON/DRY FLOOR SEASON

1. 22.5-week Ice Season

Sunday	1:00 PM – 8:45 PM
Monday and Wednesday	10:00 AM – 9:00 PM
Tuesday and Thursday	4:30 PM – 9:45 PM
Friday	2:30 PM – 8:30 PM
Saturday	2:30 PM – 9:30 PM

Hours shown here could be reduced depending on demand, always with the goal of saving a staff shift. There will likely be sufficient unused times during the hours above that additional rental demand should FIRST be accommodated only within the hours listed.

2. 12- to 13-week Spring Dry Floor Season

- Minimal schedule dry floor spring season
- Likely two evenings per week plus daytime Saturday; fill in the provided evenings before looking to expand the staff schedule.

3. 15-week Summer Season

- No programming in summer except for registered summer camps
- Available for events and rental

4. 2 weeks of maintenance

- One week to install ice
- One week to remove ice

ADDITIONAL ICE SEASON

The current proposed schedule indicates the ice will be installed between the last two weeks of October and the first week of March. This season could be moved to start and finish a week or two earlier in line with local demand, but the net usage and expenses would be the same.

The purpose of having a short ice season is to minimize the operating deficit of the facility. As there will be a need for seasonal staff, having the season run opposite to the tourist season also has advantages for staffing (as well as the availability of adult players).

There is obvious potential community benefit to lengthening the ice season. This can be done, with a cost, regardless of demand, but could also be done on a cost-recovery basis when demand warrants. The significant marginal costs are ice-operators and the extra utility cost.

As for creating additional weeks of ice use, the utility (largely hydro, to run the refrigeration plant and dehumidifiers) is estimated to be \$1,000 to \$1,500 per week, while ice rental is estimated at one-half to one additional shift per day, depending on the schedule of the use. Adding one day of administrative time per week of ice, the overall cost of an additional week of ice is estimated at \$2,500 to \$3,500. To create budget-neutral extra weeks of ice, we believe at least 16 hours and possibly as many as 24 hours of guaranteed adult rental, plus some youth rental revenue, would be required.

Public ice programs would not be held in any additional weeks of ice, as interest other than committed rental tends to wane significantly beyond the basic season.

Extra weeks of ice could be offered prior to the currently scheduled season for youth sport preparing for the season as well as adults, or at the end, adding a time of year when tournaments are popular.

ICE “USER GROUPS”/RENTERS

Adult Hockey

There were two adult men’s teams traveling to Port Alberni to play hockey, as well as a number of women, although that number has recently decreased. Time pressures created by the three-hour or longer return commute is seen as the issue. The time commitment to play at a local rink is much less, and we expect once a facility is available, those numbers will increase immediately.

It is difficult to project the exact recreation pattern that may evolve, but we expect that there will be a small recreational league and several groups that will form. Some skaters will join more than one group in order to play more each week. This is one of the reasons we have taken the approach of spreading the adult hockey rentals across the entire week. We have also anticipated one of the general adult groups to skate in the daytime, due to the significance of the evening hospitality industry.

The basic schedule will cover a range of levels of demand; for the purpose of the budget, we took the average for our high and low prediction of use.

Our more optimistic projection is 11 adult evening/weekend and three day-time rental groups per week:

- A three-team league (plus Port Alberni teams to rotate in on a very occasional basis)
- Three individual groups of men – evening (or day)
- Two mature adult daytime hockey rentals
- Two women’s teams/groups
- One weekly rental of couples and others making a fun co-ed mix

Our less optimistic projection is nine adult rental evening/weekend and two daytime rental groups per week:

- A three-team league
- Two individual groups of men
- One mature adult daytime hockey rental
- Two women’s groups
- One mixed group

The impact of having the lower versus the more optimistic level of rental use over the season would be approximately \$16,000; some of that loss could be recouped through abbreviated hours of operation. If demand were greater, potentially the ice season could be lengthened at the same net cost.

Minor Hockey and Youth Developmental Hockey Programs

Based on comparing school-aged population and hockey registration for a number of communities, we would project Minor Hockey registration to be approximately 54 to 93 skaters, slightly higher than our analysis indicated eight years ago, largely due to the inclusion of the Ahousaht community into our sample. National and provincial trends are for static numbers in Minor Hockey over the last five years after a period of decline.

	SCHOOL ENROLMENT K – GRADE 12	MINOR HOCKEY REGISTRATION	% OF SCHOOL POPULATION REGISTERED IN MINOR HOCKEY
Sunshine Coast	2912	227	8%
Port Alberni	3301	255	8%
100 Mile House	1359	180	13%
McKenzie	611	110	18%
Golden	696	93	13%
West Coast projected 7%	774	54	@ 7%
West Coast projected 12%	774	93	@12%

We have scheduled several informal opportunities to develop hockey skills through the many “Stick and Puck” or “Mini Shiny” sessions as we have called them.

Hockey Canada (Minor Hockey) has developed a number of programs to promote new participation, targeting new populations and also entry at a variety of ages. Beginning skaters have the potential to skate in a lower age group, and there is flexibility in age grouping to field full teams when registration is low. It seems this would be a benefit in the case of the West Coast, where we would hope to attract beginning hockey players through Minor Hockey while providing a challenging structure for skaters already with experience.

The West Coast is in the catchment of Port Alberni Minor Hockey (PAMH), so would naturally be part of that organization unless a change was requested and agreed upon. PAMH has expressed recognition of the need to make special accommodations and provide special assistance to this area of their region, and are eager to do so.

PAMH is offering the “First Shift” program that combines the purchase of equipment with an introductory program. We have allowed time for this program in our schedule within the allotment for Minor Hockey. There are other options for hockey development which could be offered instead of, or in addition to, Minor Hockey; we have assumed for budgeting and scheduling purposes that these would be within the time allocated.

Hockey Tournaments and Championships

Hockey tournaments, both adult and youth, create tremendous economic benefit to a community. In general, participation events are great economic generators as most of the participants come from out of town and the number of additional people traveling (especially for youth events) can bring two or more extra people for every direct participant.

In some areas of the province ice shortages elsewhere create opportunities for local clubs to bid for area or provincial Minor Hockey championships, of which there are many due to the multiple levels as well as age groupings. This is a great way to fill in demand for extra ice at the tail end of the season.

For adults, the demand for tournaments is always there, but so is the competition for hosting; it would be essential that local players work hard to use all their personal contacts to bring in teams to create tournaments that will eventually become traditions. Packaging with the many attractions the West Coast holds could differentiate this rink, and potentially bring in higher spending tourists.

For budget purposes, we have anticipated one eight-team and three four-team mini-tournaments, but no Minor Hockey championships, for a net annual revenue of \$6,000, which we have included in the adult ice rental line item.. Over time, this goal could be exceeded.

Skate Club (Figure Skating)

There is no local Skate Club at this time, and no one we have reached has indicated an interest in creating one. Unless a skilled coach already lives on the West Coast, a Club here would likely never reach the critical mass to employ one. Should there be Figure Skaters living on the coast, the best option would likely be to use a portion of the ice divided off from some of the public skates to augment practice taken in Port Alberni. No revenue or use is projected for a Skate Club.

Speed Skating

Speed skating, although popular at the Olympics, is not likely to be supported on the West Coast. There would also be equipment needs (pads) and storage for the equipment, which would rule out occasional use.

Curling

The idea of creating a temporary curling rink was well received by the local committee in 2008. Curling events are held in arenas throughout Canada, but there is significant cost to reconstruct the ice. The real value from tournaments comes in the economic spin off. In the case of the West Coast, with none of the equipment required available (as there is no local club), the costs would be much greater again.

Tournaments are generally hosted by an existing club through a bid process to Curling Canada. The Club always provides an army of volunteers as well. As such, the Coast would find itself short of a partner locally. We have not budgeted to include curling.

ICE RENTAL RATES

To create a projected operational budget, it has been necessary to assign a rate structure. These rates are considered reasonable, although they are recommendations only.

Arena rates in some northern or resource-based communities evolved from a philosophy of a one-industry town, with the concept that providing services was a corporate responsibility, and the industries paid for those services through high industrial tax rates. Cost recovery rates for recreation services are historically low in towns with high industrial tax bases, often 30 per cent or lower, even with no allowance for capital expenditures or reserves.

The Sunshine Coast, with residential contributions making up more than 80 per cent of the tax base, demonstrates the philosophy closer to user pay, whereas Gold River and Port Hardy, for instance, show the former thinking. It would be very difficult to switch quickly to more of a user-pay approach once groups organize based on lower rates.

There is also a practical aspect to setting rates for arena use; pricing ice rentals beyond the reach of groups is counterproductive to serving all the purposes of providing a public recreation facility.

In communities where ice renters do not necessarily live within the taxation area, such as in Vancouver or Victoria, adult rates tend to be closer to the full cost of the delivery of an hour of ice. Minor Sport rates tend to be higher also, but are tempered due to residential zone requirements within Minor Hockey where more in the taxed areas are the user base. An informal survey of Lower Mainland ice rates for adults indicate they vary from \$240 to \$350 per hour.

Regional norms were considered in developing suggested ice rates, as well as the reasoning or philosophy behind different communities' rate structures. Our approach for West Coast ice rental pricing is aimed at providing the most recreational opportunity for the recreating community at a tolerable burden to the taxpayer. It would be user-pay, but only within limits. We used Port Alberni, as the rink currently used by West Coast skaters as the most closely compared rinks, and moved away from some of the smaller communities that are now living with ice rates based on (former) high tax input from industry.

The difference between our "recommended" option for ice rental rates and the "lower" option would be approximately \$20,000 at the current usage, but would rise as the arena becomes more fully used.

COMMUNITY	MINOR GROUPS			ADULT GROUPS		
	PRIME TIME 2016/17	NON-PRIME 2016/17	DRY FLOOR 2016/17	PRIME TIME 2016/17	NON-PRIME 2016/17	DRY FLOOR 2016/17
Campbell River Strathcona Gardens	\$74	\$64	\$49	\$ 161	\$122	\$ 49
Comox Valley Sports Centre (SC)	\$89	\$75	\$60	\$ 164	\$122	\$ 90
Gold River	\$57	\$57	\$43	\$ 109	\$109	\$ 43
Nanaimo	\$87	\$87	\$49	\$ 174	\$141	\$ 81
Parksville (Oceanside Place)	\$90	\$79	\$54	\$ 172	\$138	\$ 75
Port Alberni	\$95	\$95	\$54	\$ 194	\$194	\$ 81
Port Hardy	\$67	\$67	\$44	\$ 112	\$82	\$ 57
August 1st 2016	\$68	\$68	\$44	\$82	\$84	\$ 58
Powell River	\$89	\$71	\$41	\$ 205	\$140	\$ 65
Sunshine Coast	\$94	\$70	\$55	\$ 205	\$150	\$ 55
WEST COAST MULTI PLEX						
WCMP - Recommended	\$85	N/A	\$45	\$ 190	\$160	\$ 65
WCMP - Low Rate Option	\$75	N/A	\$45	\$ 160	\$125	\$ 55

*From Cowichan Valley Regional District 2016 Rate Survey

We recommend that rental rates increase by a small (cost of living) amount each year, never allowing the facility to be in the position of needing to make one large increase that could damage unprepared organizations. Also, youth rates could rise towards 50 per cent of adult rate over time as organizations build the resources to finance themselves.

- **Non-Prime Time reduced rates:** Most facilities offer pricing based on “prime” versus “non-prime” times, at least for adult rentals. We do not see a need for early morning or late night hours, negating non-prime rates at this facility for many years. However, for weekday daytime use, it is likely appropriate to price lower, but not at as significant a reduction as many others. Daytime users, usually adult and especially mature adult populations, may not need significant reductions, but a somewhat lower daytime rate will encourage them to organize and rent, which is a commitment we need them to make.
- **Charges for Ice Cleaning Time:** For those wanting to use strict comparisons of ice rates as a rationale for rates, an important factor in those comparisons is whether the time required for grooming (cleaning) the ice is included in the paid time or if ice-cleans are done with the rental clock stopped.
 - The method we used in forecasting arena revenues is the norm in the mid-island; that is to include any ice-clean time within the block of use as “rental” time and therefore to be paid for. When renter groups change over, the ice-clean is provided without charge. Because there will be few “blocks” of ice rented with smaller groups, this will effectively give local groups a slightly lower rate. South-Island rinks typically charge for ice-clean time between groups, which, if instituted here, would raise the effective costs between 15 and 20 per cent for the same posted rates, as compared to the mid-island.
- **Graduated fees for new ice use:** In our 2008 Report, Recreation Excellence suggested a system of graduated (over the first few seasons) fees could be considered, specifically for sport

organizations that meet a community mandate such as sport programming for youth. It can work in the case of an existing facility trying to promote additional activity in unrented times. Over the past years we have become less of a proponent of this. It would seem that groups that are proponents of a new facility and hoping to make significant (subsidized) use of it, should be willing and eager to participate appropriately in the costs of operation.

RATES FOR RECREATIONAL USE – DROP-IN AND PASSES

Drop-in use rates for recreation facilities in British Columbia vary significantly. Although higher rates up to the point of “market value” tend to improve revenue, they can also reduce public use.

- Typical public recreation theory is to price activities so that ‘most’ or ‘almost all’ of the public can afford to make use of the facility; those few who cannot afford the use are assisted with funding.
- In practice, rates are likely more influenced by comparison with other facilities and with meeting the annual budget than by theories.
- Public rates at swimming pools are the major factor towards cost recovery; at arenas they are a very minor factor, as rental revenues are the major sources of revenue.
- There is a strong trend towards a one-rate system, where public skating and swimming are the same cost.

We are recommending public skating rates low enough that they could not be sustained later as public swimming rates as well. The idea is to put as many people into skates as possible right away. There will likely be a need to consider adjustments with a second phase aquatic centre, as the aquatic centre will rely on public admissions.

For adult hockey drop-in, we recommend a rate high enough that it does not undercut rental groups. When the ice is available only to the 20 or so that a scrub hockey time can accommodate, the individual fee should be significantly higher as compared to public skating.

- **Reduced rates:** “Leisure access” is a term in the industry for assisting those without the financial ability so they may make significant use of the facility. The philosophy is that otherwise those most needing the services of the facility may otherwise be least able to use it. A “leisure access” system will be required to optimize use across all populations.

Use cont.

WEST COAST MULTI PLEX ARENA ICE SCHEDULE

	SUNDAY	MONDAY	TUESDAY	WEDNESDAY	THURSDAY	FRIDAY	SATURDAY		
10:00		ADULT HOCKEY		ADULT DROP IN HOCKEY					
10:15									
10:30									
10:45									
11:00									
11:15									
11:30		ADULT DROP IN HOCKEY		ADULT HOCKEY					
11:45									
12:00									
12:15									
12:30									
12:45							AVAILABLE FOR MINOR HOCKEY or OTHERS		
1:00	ADULT HOCKEY	SCHOOL OR RENTALS		P & T and PUBLIC					
1:15									
1:30									
1:45									
2:00									
2:15		(ICE) MAINT		(ICE) MAINT					
2:30									
2:45									
3:00	PUBLIC SKATE and STICK & PUCK						PUBLIC STAKE and STICK & PUCK	PUBLIC SKATE and STICK & PUCK	
3:15									
3:30									
3:45									
4:00			PUBLIC STAKE and STICK & PUCK		PUBLIC STAKE and STICK & PUCK				
4:15									
4:30									
4:45	MINOR HOCKEY			MINI SHINNY and LEARN TO SKATE		MINI SHINNY and LEARN TO SKATE	YOUTH PICK UP HOCKEY	MINOR HOCKEY	
5:00									
5:15									
5:30			MINOR HOCKEY		MINOR HOCKEY				
5:45									
6:00									
6:15									
6:30							ADULT DROP IN HOCKEY		
6:45				MINOR HOCKEY		YOUTH THEMED PUBLIC SKATE			
7:00			ADULT BEGINNING HOCKEY (instructional)						
7:15	ADULT HOCKEY								
7:30									
7:45			ADULT HOCKEY				ADULT DROP IN HOCKEY		
8:00									
8:15								ADULT HOCKEY	
8:30									ADULT HOCKEY
8:45				ADULT DROP IN HOCKEY					
9:00									
9:30									

PUBLIC PROGRAMS

Ample opportunity to skate recreationally and to receive instruction in any of the skating disciplines is an important part of any ice facility. For many recreational skaters, this is the only use they will get from the ice facility; for others it is the bridge to becoming a hockey player or perhaps a competitive skater.

Too often public programming is minimized due to pressures from rental groups. Although those pressures may be exerted by rental groups someday, there will be, for the foreseeable future, ample ice-time to offer public programs at the West Coast facility. The challenge for this facility will be to use the public program time to develop more skaters and therefore more customers.

Our sample schedule doubles up public skating with skate lessons or children's "stick and puck" whenever possible both to make efficient use of the time and to create cross-interest in the activities. We have budgeted for a rink divider to create a safe, fun atmosphere that is enhanced by the combining of activities.

Public Skating

Public skating is an important community service. We have taken the view that public programming will be provided, and then extended for as many hours as it can self-finance. Public skates can be more than just skating in circles. They can, and should, include some programmed activity and even a bit of informal instruction. Supervision is required to maintain safety and decorum, especially with mixed ages and skill levels.

There are a number of approaches to staffing public skating within the industry. In the case of the West Coast, we have projected attendance sufficient that Public Skates, other than daytime skates, will likely warrant supervision on skates.

The Skate Shop would be available during public skating sessions and during skating lessons, sessions of hockey instruction/development and school and community recreational rental groups. There would be a mix of times when a staff is stationed directly in the Skate Shop (also likely to receive admission at that location), but in slower times, it would simply be the ice operator retrieving skates from the skate shop and accepting them back at the end.

It may seem intuitive that there should be net revenue from public skating and especially from the skate shop. In a larger market, where a public skate may draw upward of 100 skaters, this should be the case. However, with a small population/skating base, we project up to 40 skaters for Public Skates and less for daytime skates, for an overall average of 25 per skate. With these numbers, the revenue will offset the cost of staffing the skate shop and providing skate hosts on the ice where appropriate.

- If the attendance is less, it may be necessary to offer fewer public skate sessions when operating hours could be saved, also there may be some skates where staffing can be limited, making it more economical to offer.
- If attendance is higher, more hours of public programming can be offered within the same net annual budget.

Public "Scrubs" – Drop-in Hockey

"Scrub" or "shinny" hockey on a drop-in basis is a service, a revenue source and an important hockey development program. It accommodates those who do not have the time to join a regular rental group, lack skills, or just want more ice time to play hockey. As a developmental program, it will be important to actively promote hockey.

We recommend, for adult sessions, appointing one of the skaters "supervisor", meaning that person does not pay to play, and is responsible to maintain basic decorum and uphold safety guidelines on the ice and may be asked to collect fees. This is accepted due diligence in terms of safety-supervision, as long as there are clear rules and reasonable checks in place, and it replaces the need for supplying a staff member. For combined Public Skate and Stick and Puck, a host should be on the ice, to supervise both activities.

The limit on providing drop-in hockey especially during weekday daytime, is not so much staffing but fielding enough skaters to create a "game". We have scheduled five sessions of adult drop-in

hockey per week; more could be accommodated and times shuffled to match peak demand. We have not scheduled specifically a female Scrub as it could be self-defeating if there are not enough skaters to support it; sessions would be mixed.

Revenue is projected based on an average 14 paying skaters per session, with goalies and the “Scrub Supervisor” not paying.

Adult Developmental Hockey Programs

Developing adult hockey is an important recreational mandate especially in a community that does not have a traditional hockey base. Typically, adult developmental hockey program would be 10 or 12 sessions, starting with basic skills and developing to hockey drills and strategies, and scrimmages, encouraging the participants to move into playing in a league. Volunteer instruction could lower the fees as well as enhance instruction. We have budgeted on \$9 per participant (same as the drop-in hockey rates) within the fee to attribute to ice use.

Learn to Skate

Learn to skate programs are projected for two times a week, each with enough time to offer two or three back-to-back lesson times. The number of instructors will depend on demand; we would expect there will be two in most cases. We have allocated skate instruction to share the rink (divided) with other activities to make best use of the ice and to cross promote activities.

Standard methods of providing skate instruction are:

- Skate Canada’s CanSkate program – offered through a Skate Club
- Arena operated learn-to-skate program

As we did not project a Skate Club to evolve at the onset, learn-to-skate would be offered in-house. The arena program wing would likely contract skate instruction to one of the communities or to an individual. In our initial research, we have found an interest in volunteer instruction, which could be combined with paid leadership to provide affordable ongoing instruction. A lead skate instructor would likely be appointed to oversee lessons while also instructing a class.

One option is for Ucluelet or Tofino to provide promotions and registration, either as part of a contract to operate learn-to-skate or on a fee-for-service basis with a separate contract provider doing the instructing. Neither Ucluelet nor Tofino has agreed to provide the above services, so it may be necessary to provide the entire package at the arena under a contract to interested instructors.

School Rentals

Schools will want to make use of the ice arena; we have budgeted one hour per week for school rental. The key to school use may be carpooling, to avoid the high cost of bussing. One rental hour per week is budgeted, which would be an average of one to two visits per year. We consider school rentals a “program”, as there should be hosting and informal instruction at least roving school rentals to ensure all children get value out of the experience.

We assume that the Reciprocal Use Agreements in place with schools would not carry over to the arena and eventually the pool, so we have included rental income in the budget.

Dry Floor Rentals

Ball hockey, and inline hockey, lacrosse, soccer and roller derby are main dry floor public programs in many arenas. Adult daytime use of pickle ball and badminton are gaining popularity in some areas, but are not projected for this facility. The dry floor sport use of the facility is important to the community, but can be accommodated with an abbreviated schedule, reducing costs of operation.

We have scheduled hours for drop-in programs and for sport rentals during the dry floor season without attempting to predict specifically which programs will succeed; three evenings a week plus a block of time on Saturday. An arena is a large floor space, so programs may share the facility floor, using the rink dividers for safety.

It is to the arena’s benefit that as many of these activities as possible are primarily accommodated with rental groups, removing the risk of low attendance and the cost of supervision. It would be far better that the community steps up and organizes these, as opposed to program staff.

Ball Hockey: The success of ball hockey across the country is varied. Decreased equipment and rental costs, as well as not requiring skating ability, provides great appeal. Some areas find that the program competes poorly with local minor baseball or soccer. The West Coast has a history of a solid ball hockey organization. There were a number of youth teams, and eventually adult teams as well. A lack of available facilities is reported as the cause of ball hockey losing some of its local popularity, so there is some anticipation that interest will return.

Ball hockey can be offered as drop-in, in a tournament format, or as a league. Drop-in formats, unless championed by someone with strong community ties, tend to run out of steam over the spring. Youth tournament events may be the best way to develop interest in ball hockey until a league can be developed. Because skill development is not necessarily as big a part of ball hockey as compared to hockey, it can successfully be offered as a registered league without having as significant a volunteer hierarchy. For adults, a registered weekly time works well without further formatting or the numbers required for a league.

In-Line Hockey: May succeed as an adult program for the adult hockey players who want to continue into the spring. In-line can be offered as a program (registration as opposed to drop-in is recommended) or a league rental. It will likely be one session, once or twice a week over the spring season.

Roller Derby: A common female sport in arenas, it often brings spectators, which increases the value of the facility to the community. There has been a roller group on the West Coast, so it is likely there will be a small organization during the dry floor spring season and possibly even in the quiet summer season.

Lacrosse: In 2008, we heard community interest expressed in organizing lacrosse. We have not heard of any in this year’s research, and now feel it may be ambitious to schedule rental revenue based on lacrosse. There is certainly floor time available, should the community respond.

Indoor Soccer: The West Coast has a significant soccer interest, although demand for indoor use would likely be highest during the ice-season, soccer could be played in the spring rental season. As well, there may be a chance to create tournaments.

A soccer “turf” is expensive and a major effort to install or remove; there is no storage or loading capability within the facility. A turf is not planned.

Basketball: Not a common youth sport on arena floors, we understand that there is significant interest in the communities of Esowista and Ty-histanis and other local First Nations, so we have budgeted for a set of reasonably priced and very portable basketball hoops, which could fit with other activities on the dry floor.

Badminton, Pickle Ball: Daytime adult use of dry floor arenas in some communities has increased significantly; badminton and pickle ball are growing sports with reasonable set up costs. However, both Tofino and Ucluelet offer pickle ball; Ucluelet offers badminton. We do not see any opportunity or reason to compete with the programs that are currently evolving within the two communities.

TOURNAMENTS, TRADE SHOWS, AND EVENTS

The community has indicated the Multi Plex will be used in a number of ways beyond sport use. They may take time to evolve, but additional uses can bring significant cultural and economic value to the community. Most of the alternate uses of the facility would happen during the ice-out season.

1. SPORTS TOURNAMENTS

Tournaments that would be generated by the local adult teams or Minor Hockey with four or eight teams are included as part of the ongoing ice use and budget. The tournaments described below would be beyond those created by User Groups.

A. Major Hockey Events and Tournaments

It is possible to install ice strictly for a group, but the additional expenses are significant. Installing the ice early or extending the ice season are less expensive options. Alternatively, even major tournaments can be timed during the season, arranging with regular users to rearrange their schedules as necessary.

- Hockey based films and TV shows
- Preseason camps for professional or junior level teams

- Celebrity hockey camps aimed at high dollar participants
- Major hockey tournaments developed over a number of years, either targeting players with ability to pay (First Responders/medical professionals, professional associations) or funded corporately as incentives to employees.

B. Dry Floor Tournaments

- **Basketball Tournament and Camp:** There is a potential to create a basketball tournament during the spring or summer season. Even though a concrete floor is not appropriate for an adult full-court game, a 3 on 3 (half-court) tournament could be held. There are several pre-packaged tournaments in existence; the recommendation would be to partner with one of them as a first choice. The arena could easily handle six half-courts with room for spectators, administration, merchandising, and food and beverage service. The basketball standards required are the lesser-sized mobile units; extras could be borrowed, rented or supplied by a tournament partner and could become a tourism standard over the years. We have projected the arena will want to own two such standards so that basketball on a slightly undersized court could be offered as part of dry-floor programming. A basketball camp for West Coast youth could also be held in conjunction with a 3-on-3 tournament, creating more direct local youth benefit.
- **Ball Hockey, Inline Hockey, Roller Derby, Soccer:** Any of these activities can be built into a dry floor tournament during the spring season, either as low key events run by the local teams, or on a larger scale, possibly with a charity or corporate entity to capture a group of participants who would come for the overall activities more than just the games. We have budgeted for two such weekends each year, each on a conservative scale.
- **Wrestling Tournament:** Ucluelet Secondary is the local organizer of wrestling activities. Ucluelet has hosted the Vancouver Island School Championships some years, and feel they would pursue the Provincial Championship if an arena-sized venue was available. One issue for bidding on the Provincial Tournament is that the date is the end of February through very early March, potentially a conflict with the end of the ice season. Also, schools usually host championships without a rental fee. We have not projected net revenue to the facility for wrestling as this would be on a very occasional basis.

2. TRADE SHOWS AND CONVENTIONS

Regionally industries that rotate their annual events around their market area are typically the first bookings for trade shows and conventions at a new facility. The arena floor will be sufficient to attract any groups who require a large space for commercial exhibits. Logging, fishing and tourism events should be pursued.

Local committees, such as service or other clubs can organize their own regional, provincial or national gatherings. Some of these would be suited to the Ucluelet Community Centre, whereas events such as car clubs would need the large floor of the arena for display.

“Turn-key” events, including home shows and seminar groups, typically work with experienced event sales persons, such as those employed by West Coast resorts. Local businesses may also choose to take their business to the next level with a major display sale or promotion event.

Importantly, the Multi Plex would defer to Ucluelet for events they could more effectively host, and now partner with Ucluelet to co-host more complex events that would use both facilities. The Ucluelet Community Centre is a major facility purpose-built to include mid-sized events; it is better suited for most of these and depends on them as part of its business plan.

There is often pressure for rent and set up charges to be discounted for an event; the end price a promoter or event pays for the facility may indeed be discounted, but not at the expense of the facility if it is expected to operate successfully.

An approximate value to the community of a two-day meeting with 600 out of town participants can exceed \$200,000, and could be much higher in a destination such as the West Coast.

3. CONCERTS AND ENTERTAINMENT EVENTS

It has been noted that performers want to come to the West Coast, as would potential audiences. The concert business is a risky business however, and much more so for facilities not on a regular circuit. The West Coast isn't "on the way" to anywhere, so there would be transportation costs both "to" and "from" shows. The expense of two-way travel from the nearest other show locations would make shows with significant equipment less likely. It would also raise the cost to the promoter for staging, lighting, sound and seating beyond what would likely be affordable. Pre-wiring the facility to easily support shows is expensive, and would likely not be part of a reasonable building design. Currently there is no history of major concerts on the West Coast, and no local promoter working on the scale required.

Some entertainment events may make sense for the West Coast especially concentrating on acts where the floor could be partially utilized for seating, raising capacity to 1,000 or more. It is possible that, in the summer, tourism would support this but it would require teamwork in marketing with resorts and the tourism agencies. We cannot predict success with hosting concerts and other entertainment events; it would be up to the hosting agency or business to create a viable business case.

Services such as security, ticketing, production equipment and staging could be rented; Ucluelet uses a service in Parksville.

If, despite the challenges, it is the community vision that the facility will house significant "events", its design will need to be enhanced. The fire systems will need to go beyond the basic design – arena boards with certain sections that can be removed easily to create open exits, storage areas increased, loading areas enlarged, etc. These would come at additional cost, and would only be worth that cost if the value to the community is deemed great. As a pay-back for the facility itself, it is not likely to be financially sound. The recommendation is that design features that enhance servicing major events are considerations within the final business plan and that they are done in, at most, a modest way.

4. CULTURAL EVENTS

With five First Nation entities on the West Coast, and the facility situated in the midst, there is a potential for any or all to hold major cultural events on the arena's 17,000-square-foot floor, especially March through September. The combination of First Nation local history and culture with an exciting destination could also lead to drawing cross-cultural events with other First Nations communities or other cultures.

Cultural events could be the most common major gatherings at the Multi Plex. Many participants are already on the West Coast; the numbers attending would already be significant, and there are many groups that could work together to bring other participants from farther afield.

The lack of several break-out rooms would likely not be a major issue to cultural gatherings, as staging rooms could easily be created by using a storage container located outside to temporarily store arena equipment and converting existing storage rooms for alternate uses.

Cultural events are likely to be the most common major event at the Multi Plex; they will be locally generated, the nature of the events might lend themselves best to the open floor space, and the location is within minutes of the group likely to at least share in hosting. Without major set-up expenses, the facility will be more affordable than for a trade show, for instance. Not primarily aimed at profit, and with low set-up costs, these events pose less risk to the sponsor, and therefore are more likely to happen. The positive impact on the community will be social first and economic second, exactly as a recreation facility is meant to be.

5. EMERGENCY CENTRE, EMERGENCY STAGING, EMERGENCY SHELTER, DISASTER RELIEF

The site is a natural location for a disaster relief centre and gathering place. Currently it is located at one of the higher group gathering points.

With power and water service working, the arena can hold ice, if it is in, and still provide significant lighted, warm sleeping areas, showers for many people and a staging area at the airport

for supplies, evacuations, reinforcements, a mass morgue and other functions as necessary. The entire rink cold area could be used as a giant cold storage area for any purpose needed.

With power out if ice is installed, how long the ice will hold would depend on the external temperature, the opening of doors and traffic inside. It would eventually become slush, then a pond, and take days to be cleaned up and dried out.

As the refrigerant used will likely be ammonia, there needs to be some consideration made in case of a release, which could make the area a hazard, not a shelter, until rectified. Ammonia does clear itself in the atmosphere, so any such problem would be temporary except in the case of an ongoing leak.

Perhaps federal funding could be accessed to enhance any required amenities and to create safeguards such as back-up power (sufficient only for building operation, not holding ice or heating many showers), loading bays, etc. as required; we have not investigated this possibility.

6. HOSTEL, SEASONAL STAFF RESIDENCE, EMERGENCY ACCOMMODATION

We received suggestions previously that the ice-area facility may become a residence for seasonal staff. To expose the building to the types of stresses such a use would bring on is not recommended.

The floor itself is 17,000 square feet, there are six large change/washroom/shower areas; this could in fact be a very valuable use of the ice facility in the off-season. As such it could become very valuable to house people for a “one-off” event when people must be housed for a short period of time. It is not seen as a regular use of the facility however, and would likely not even be fully certifiable for that purpose.

ADDITIONAL AMENITIES AND EQUIPMENT

Fitness Centre: Although a fitness centre is not a natural fit for a single sheet ice facility, when an eventual aquatic component, where fitness programs, including a variety of floor classes and a cardio/strength facility are the norm is developed, the mezzanine could serve as a less expensive alternative compared to building additional new floor space. This would create an important feature for the Multi Plex without additional construction cost (except an elevator, if that is delayed at initial construction) at that time.

Mezzanine Area: Depending on the design chosen for the ice facility, it may be a relatively inexpensive proposition to convert a mezzanine area above the lobby of the facility into an area for public use.

- General viewing, meeting rooms, lounges, and program rooms are common uses for mezzanine space in public ice rinks. However, Tofino and Ucluelet hold their programs within their community. There are also additional meeting spaces at the Golf Club and at a local resort. At this point, there would be little need for programs or viewing in a mezzanine.
- At one time lounges were almost ubiquitous on the Canadian hockey scene, but now it takes at least a busy twin rink or a Junior Hockey level team to consider one. A lounge is not necessarily how community recreation facilities want to position themselves today. There are also complications in applying for a special event licence when a facility has a permanent liquor licence. A lounge is not seen as a good fit for the Multi Plex.
- A mezzanine would create an additional supervision area without the staff to oversee it, and would require daily cleaning. It would become a locked area except during special occasions.
- Major meetings, trade shows, cultural gatherings, could often use additional, separate space, such as a mezzanine. The number of times these events that need that space would not likely warrant developing it on an economic return basis, but it would be a feature that might help secure an event at some point.

If a mezzanine area was included within the basic facility design (a Sprung Structure, for instance, where there is a natural space above the lobby area), consideration should be given to include stairs and an elevator, or to include stairs only, with an elevator to be built in the future, accessed off the eventual pool lobby. Without an elevator, the public could not use the mezzanine, but it could be used for storage.

COVERING THE ICE

To hold alternative events during the ice season, an over-the-ice flooring system would be utilized on a temporary basis. There are two standard types of arena ice coverings:

- Homasote flooring system, a wood composite material, which sells with a racking system for slightly over \$100,000.
- A variety of rubber systems (lasts longer; more comfortable) with varying grades from \$110,000 to \$210,000, plus tax.

Flooring requires a forklift to put in place, at about \$20,000 for a good used machine. A permanent storage area would need to be built, at about 800 square feet, with modified doors to the ice machine corridor so the forklift can maneuver. For flexibility removing the boards and glass, a more advanced board system may need to be specified and a storage rack system for the boards would be needed. The initial investment, all in, would be \$300,000 to over \$400,000 for the additional space plus the equipment.

Converting the facility (flooring, some glass and expanding exit routes by removing key arena board sections) would take a crew 40 or more hours of work, both prior to and after the event.

When an event requiring conversion is booked, the cost of conversion is charged back, a minimum \$2,000 additional rental charge for a two-day event in this case. Also, the ice use lost would need to be recovered. Most of the additional costs would not be incurred when the ice is out. When flooring is required for a trade show or similar event, there is usually also a need to rent pipe-and-drape dividers, carpeting, stage and sound system, plus a technical crew to install and operate those.

It should be noted that Port Alberni has sourced a used Homasote floor, so we recommend negotiating rental of the floor from Port Alberni. A semi-trailer delivering it could be used for storage during the event, the theory being that an event that would spend the \$2,000 conversion cost could probably also afford the additional cost of renting the floor, lessening the initial investment at the arena.

If the ice were to be removed and then restored during the ice season, as opposed to covering the ice, the time lost for the process would be one to two weeks. The cost for additional labour, and utilities would be in the area of \$5,000, plus lost rental revenue, and could have an impact overall on some ice-sport seasons.

With the economics of covering or removing the ice in mind, it speaks to the focus for major events to be during the ice-out season.

FOOD SERVICE

In our initial discussions, Recreation Excellence recommended against a staffed food concession at the arena, even when an aquatic centre is added. We were asked, however, to investigate a food service option specifically for special events.

The Ucluelet Community Centre was built with the ability to serve banquets. Our recommendation would be to compliment the Community Centre, not compete with it, and augment its draw by targeting events that would need a bigger floor space, but would hold a banquet at the Community Centre. We have not surveyed the banquet capabilities at commercial locations on the West Coast, but the same principal of working together, not competing, would apply. A West Coast caterer has indicated that events of up to 250 people could be catered using hot boxes, so without warming ability.

Installing a commercial kitchen requires plumbing, electrical and ventilation plus the fridges, ovens, cooking surfaces, counters, dispensers, etc., at a cost of more than \$200,000. Catering to groups larger than 250 typically requires these services at the location, which we have not included in this proposed budget. A much lesser arrangement has been budgeted for, which includes a residential freezer, two fridges, a coffee set up and a double sink. The plumbing for the sink is not budgeted for, as we have not reached that level of design finishing and would hope it could be situated in a room close to plumbing features.

SEATING

It is not necessarily true that the more spectator space the better. The positive aspect of more viewing area is obviously the ability to accommodate spectators on the occasion of events suited to the public attending in significant numbers. However, more bleachers or seats require more ventilation, more cleaning, more painting or repairs, and more area to supervise. Also, seats, as opposed to bleachers, significantly complicate sweeping and mopping in the spectator area as well as require repairs that bleachers do not.

Some arena designs allow for more bleachers simply because the provided solution for dressing rooms is to place them under the spectator area. If this is the design model, we would support extra seating. Otherwise, a minimum of space for 200 spectators is recommended and more do not significantly add value to the facility. Our preference is toward bleacher seating over individual seating, even not considering the cost advantage, but other views have validity as well.



Budget

WEST COAST MULTI PLEX ARENA BUDGET

The overall budget to determine the level of tax support the facility will need is comprised of three areas:

1. **Operating Budget** - all annual revenues generated and the expenses associated year over year with regular operations.
2. **Capital Maintenance Plan** – Life cycle repair, maintenance and replacement of components of the facility are budgeted over 50 years and required money is reserved in a budget fund that will save in low-expense years so as to have the funds available when major expenses become necessary.
3. **Capital Replacement Fund** – Local governments are required to build funds in preparation to eventually replace assets such as recreation facilities. The fund is built by reserving replacement funds each year out of the overall budget.

1. OPERATING BUDGET

The projected operational budget reflects user demand similar, based on the population, to other island communities, but with higher revenue due to ice rental rates closer to those in Port Alberni. The operational deficit is also anticipated to be lower than some of the island rinks due to the proposed plan to limit expenses through containing the operational dates and hours to match the demand, as well as maintain reasonable wage rates and staff scheduling flexibility.

Projected annual figures for operations are \$121,791 in revenue, with operating expenses of \$346,761. The annual operating deficit would be \$224,791.

OPERATING REVENUE

Skate Rental and Sharpening – One in three public skaters and lesson participants are expected to rent skates. The target is for skate sharpening is 250, about the number that could be done by ice-men ongoing during their shift; beyond that staff brought in to sharpen skates would likely be at a break-even basis.

Advertising – 10 board ads @ \$400 per year (after manufacture and installation cost); eight digital lobby ads @ \$300 per year. Any further advertising, such as print, would likely be in-kind support of flyers, etc. or would go to individual groups or event budgets.

Vending – Revenue will be positive during the ice season, but stale-dating at the end of the season and during the spring and summer season would offset some of the gains. Selling hockey tape, laces, mouth guards, etc. would help and is budgeted for.

Rental and Program Revenues – details are contained in the “Public Use” section of this report.

Skate Rental and Sharpen	\$3,452
Advertising, Sponsors	\$6,400
Vending (Net); Other	\$1,500
Ice Programs – Public Skate and Drop In	\$24,564
Dry Floor Programs	\$1,650
Rental Ice – Youth	\$19,125
Rental Ice – Adult	\$60,300
Rental Ice – Other	\$3,300
Rental Dry Events	\$1,500
TOTAL OPERATING REVENUE	\$121,791

OPERATING EXPENDITURES

Ongoing operational expenditures without the Capital Maintenance Plan and Capital Replacement Fund are usually referred to in the annual operating budget.

Administration

Bank Charges – \$3,000. Charges should be relatively minimal due to the small number of deposits and limited credit card usage. (Ice rates would likely include a surcharge for credit card when used for ongoing rental contract payment.)

Advertising – \$2,000. This is to allow for charges from local governments if there are fees for inclusion in Leisure Guides and occasional newspaper ads; it is assumed that posters, schedules, etc. could be sponsored in-kind.

Insurance – \$16,000. Anticipated cost of building insurance is \$13,000. The additional \$3,000 allows for participant insurance that would be necessary if operated by Tla-o-qui-aht First Nation. The ACRD would not pay participant insurance, as part of the Municipal Insurance Association, and would save the \$3,000.

Licences, Dues, Permits – \$2,500. This is a middle estimate; the total will likely be higher or lower by approximately \$1,000 whether Risk Assessment is necessary.

Office, Shipping – \$1,200. Allowance of \$200 per operating month; it is not anticipated that significant office functions would take place at the arena.

Phone, Internet, Alarm, Computer – \$3,000. One business phone line including long distance, internet and alarm monitoring are budgeted at \$250 per month. An additional \$50 per month is allowed for basic computer software, computer upkeep and alarm report or call out fees.

Administration	\$25,000
Bank Charges	\$3,000
Advertising	\$2,000
Insurance	\$16,000
Licences and Dues	\$2,500
Office; Shipping	\$1,200
Phones, Internet, Alarm, Computer	\$3,000
TOTAL ADMINISTRATION	\$52,700

Salaries Wages and Benefits

See the Staff section of this report for Salaries, Wages and Benefits details.

Management and Supervisors	\$40,000
Ice Operators	\$108,339
Program Staff	\$16,422
Uniform (or Allowance)	\$800
Training/Workshops/Seminars	\$3,500
TOTAL WAGES, BENEFITS, TRAINING	\$169,061

Utilities

Hydro; Propane; Nat Gas – \$60,000. General energy efficiency including the use of either a prefabricated insulated panel construction or Sprung Structures, should reduce electrical costs as compared to most of the comparison rinks. The projected ice season is at least as short as the comparison arenas as well. Heat recovery systems should mitigate costs in regard to the lack of natural gas for heat, keeping the West Coast facility costs at the very low end of the small community rinks we surveyed. Propane will be used for the ice resurfacer as well as the building heating that is required. Here again, a short season will keep propane costs low.

Water & Sewer; Garbage - \$6,000. Detail of the sewer design (septic or sewer) and water supply rates are not known; a typical costs are budgeted.

Hydro; Propane; Nat Gas	\$60,000
Water & Sewer; Garbage	\$6,000
TOTAL UTILITIES	\$66,000

Operations

Vehicle – \$5,000. The budget is for both the charge-back for vehicle use by the operator plus kilometres claimed by any staff required to travel in their own vehicle. With a short season, it is more economical to operate without an arena-owned arena vehicle.

Safety – \$2,500. Work boots, safety gear and equipment.

Supplies & Materials – \$18,000. This includes janitorial, program and materials for repairs in general. The consumables will be relatively less than many rinks due to the short operating season.

Repairs and Maintenance – \$24,000. The building will be new, and costs should be low for a number of years. (The Start Up budget includes money for carpentry and other initial work over the first year or so.) Scheduled refrigeration plant maintenance, replacement tires for the ice resurfacers, etc. are included in the Major Maintenance plan, separate from the operating budget, whereas in many arenas these would be unbudgeted, and therefore come out of operating expenses.

Grounds and Parking – \$4,000. The parking lot will be new; we are assuming no initial upgrades or repairs. We have anticipated minimal snow removal, something that may be more of a factor in other rinks we have compared. Five- and ten-year capital work on the parking lot is included in the Major Maintenance Plan.

Equipment Rentals – \$2,500. Occasional need for ladders or lifts, arena floor scrubbing, etc.

Contract Labour – \$3,000. Trade work such as electrical or plumbing, and an annual ice plant start up service.

Vehicle	\$5,000
Safety	\$2,500
Supplies & Materials	\$18,000
Grounds and Parking	\$4,000
Repairs & Maintenance	\$24,000
Equipment Rentals	\$2,500
Contract Labour	\$3,000
TOTAL OPERATIONS	\$ 59,000

2. CAPITAL MAINTENANCE PLAN (CMP)

Major components of both the building itself and all the systems, have limited life expectancy. Along the way, beyond the regular Preventative Maintenance and minor repairs, there are also expected time lines for major rebuilds or services. Other things just become dated to the point of replacement being an obvious necessity or desirable operating strategy.

Unexpected or unfunded major items can run any given year's annual expenditures far over budget. For this reason, an ongoing fund to prepare for major repairs and replacements is required.

Needed major repairs and replacements if unbudgeted often go undone, leading to everything from recurring problems (rentals cancelled due to ice resurfacers breakdowns) to catastrophic failures (chiller failure; inability to make ice). Funds for the CMP are reserved annually and held over separate from any budget surplus on a year-by-year basis.

Experience tells us that some of the items on this list recur like clockwork, while others can surprise for better or worse. It is not suggested all the indicated budget items are adhered to if evidence indicates they are not yet needed, but the CMP included is meant to ensure funds are available within the overall budget allocation on an ongoing basis.

Budget cont.

Notes

As shown in the CMP, it is anticipated the fund will grow, then be diminished at around what is typically the first mid-life re-build of the facility – around 25 years – and then build up again until those components age.

In many cases, the large expenses at midlife are rolled into expansion and modernization. Often the debenture initially taken to fund a facility is paid off or paid down at 25 years and a new borrowing initiative is instituted to renew, refurbish and enlarge. In these cases, noting that many major expenses fall around the 25-year mark, the ongoing CMP can be funded with much less of an annual contribution. One strategic note in favour of taking this unfunded approach is that there are often grant opportunities both for the new construction aspect and for upgrading components to greener options, which should be available at that time. Aspects that would likely fall into a green initiative could include lighting, envelop repairs, lighting and HVAC.

It is recommended that a CMP based on the one provided but more specifically targeted to the equipment specified at the time of design be put in place initially. After a period of 10 or 15 years, alternate strategies around funding major maintenance and midlife rebuilds could be considered, possibly allowing the fund built up to be partially moved to a capital replacement fund to be used toward the owner's portion of funding a mid-life project.

The CMP includes the 50th year, to fully fund the period where the building would likely go through a second refurbishing. The 25-year strategy could be employed again, with an eye to keeping the facility useful for yet another 25 years. Alternatively, some things would not be replaced, unless necessary, as the community looks toward a new facility, and the Capital Replacement Fund would be fortified on an ongoing basis.

The annual commitment to the Capital Maintenance Plan we have budgeted for to meet the 50 year need is \$43,663.

3. CAPITAL REPLACEMENT FUND

It would be prudent for local governments to plan ahead for replacement of major assets through Capital Replacement Funds. It is essential that a reasonable Replacement Fund plan is integrated into annual funding. The challenge is finding a balance between raising a partial or the full amount anticipated to replace the facility versus the need to fully fund the annual operation to ensure optimal use of the facility.

Percentage of Revenue: Some communities apply a set percentage of revenue towards capital replacement. The City of Port Alberni retains an amount equal to 10 per cent of revenue; in the Multi Plex’s case that would be about \$12,000 at first, and grow with usage and as fees increase with inflation. This would never result in a fund that would actually replace the facility, but could be seen as a realistic commitment. If this path was chosen, it could also be enhanced by promoting this as an additional charge to use fees, raising rates to some degree to show the need for user groups to participate in funding.

Percentage of Replacement Cost: If the community wishes to have, at the time the facility is replaced, a set percentage, or the total cost of replacement, the annual contribution could become much more significant than the percentage of revenue approach.

Any saving for Capital Replacement would involve anticipating some grant support from higher governments and likely some local fundraising. With that in mind, the target for money “in the bank” might reasonably be 50 per cent of replacement cost, in order to avoid further local borrowing at the time.

The ACRD has instructed for the purposes of this budget that we plan to reach 50% of the current replacement cost over the life expectancy of this facility. Assuming the cost of replacement on an existing location with site servicing already in place to be \$9 million in 2017 dollars, and the life expectancy of the facility to be 60 years, the annual contribution to reach 50%, or \$4.5 million, is \$75,000 per year.

The annual commitment to the Capital Replacement Fund we have budgeted for, with consultation with the Alberni-Clayoquot Regional District is \$75,000 each year.

Annual Operating Expenditures	\$346,761
Annual Operating Revenue	\$121,791
Annual Operating Net Deficit	\$224,970
Capital Maintenance Plan – Annual Commitment	\$ 43,663
Capital Fund – Annual Commitment	\$ 75,000
TOTAL TAX SUPPORTED COST ANNUALLY	\$343,633

Operational Budget Comparisons

Recreation Excellence was asked to review the operations and budgets of a number of other rinks to assist in preparing our operational budget. We looked at over one dozen rinks, and have used 11 directly as comparison rinks.

The rinks we have surveyed show that single sheet arenas will run with operational deficits, of \$150,000 to \$200,000 for busy rinks and \$200,000 and above for smaller communities. Wage rates, the operational season and the hours of operation versus hours of use are factors in keeping the deficit manageable.

Low ice rental rates can have the goal of positively impacting use, but can result in a negative impact on revenue. In communities with minimal use, there is little potential to improve the overall financial picture significantly with rates, but in a well-used facility they are key.

Overall, the budgeted operational deficits in our sample ran between \$167,000 and \$370,000. A review of the operational factors shows the variances are understandable and give credence to the projected budget deficit on the West Coast to be toward the lower end of the scale, providing wage rates are as projected and the operation is kept in scale with demand.

Gold River

Gold River's population has remained steady for the last 15 years at around 1,300, one third the West Coast population catchment; as a traditional hockey community, rental use is approximately 70 per cent of our prediction for the West Coast. The ice rental rate is low at \$109 for adult and \$57 for youth use. A direct comparison on same use, but at West Coast proposed rates, would result in rental revenue for Gold River moving from \$43,000 to close to \$73,000. Considering the population difference, and the solid young adult population on the West Coast, our projections seem relatively conservative.

Staffing costs in Gold River are attributed differently than in the projected West Coast budget. Gold River does offer some early morning ice times to their Skate Club in spite of open hours at other times, running two full shifts most days. Also, without making an exact comparison, labour rates are higher in Gold River. Where Gold River does save is that they operate very limited dry floor activities, plus they allocate some of the staff costs to their Community Centre.

On the expense side, the two budgets are very similar except we have budgeted a cost for administrative functions that are not allocated to the arena in Gold River's case. The end result is a higher deficit for Gold River due to the lower use and lower fees.

The result for Gold River is revenue lower by \$68,000 and a higher deficit by approximately \$45,000 as compared to those projected for the West Coast.

Port Alice

What happens when a rink is used very little? Port Alice suffered a population drop of more than 50 per cent to between 1980 and 2010. The percentage of the population between 20 and 44, an age bracket that best supports an arena, both as participants and as parents, dropped over 15 years from 42 per cent to 26 per cent. What is left is very little Minor Hockey and four adult groups; the only growing use area is female hockey.

This sort of collapse is not anticipated for the West Coast, but the Port Alice budget does show that the base level of deficit, around \$200,000, can be maintained with the approach that there is only so much money available and the program can be adjusted to stay within that budget.

Port Hardy

Port Hardy's population base is similar to the West Coast. Ice rates are much lower, low enough that revenue is less than we have projected in spite of higher usage. Staffing is two shifts most days, but the lead staff is responsible for one shift week days.

Significant savings in the operational budget are due to staff sharing duties with a pool and civic centre. Creating efficiencies, minimizing spring hours and not charging significant administration fees to the arena budget.

Operational Budget Comparisons cont.

To compare the Port Hardy budget to the West Coast, the deficits would be very similar if one were to charge the administrative costs back to the arena, use the West Coast rates and remove Port Hardy's efficiencies in charging staff to other functions.

Princeton

The ice rental rates in Princeton are \$85 for adults and \$47 to \$50 for youth. At West Coast rates, the same use would translate into approximately \$150,000 revenue instead of the current \$74,000. Staff costs are also much higher in Princeton; the breakdown of those costs were not explored, but the hours of operation are longer compared to the West Coast operational plan.

The result is a deficit of \$100,000 higher than we have predicted for the West Coast, split between ice rates and higher staff costs.

Sechelt

The catchment for the two Sunshine Coast rinks is approximately 30,000; the population is older, with only four times as many school aged children but six times the population. Ice rates are slightly higher in Sechelt; revenue is 50 per cent higher. The SCRCD distributes administrative costs among functions.

Arena staffing is at a higher level than our West Coast projection. Sechelt operates two full shifts most days despite open times during the evening, raising staff costs. Labour rates are also higher compared to our predicted West Coast rates.

The Sunshine Coast Regional District distributes overall administrative costs among all its functions, as we have projected to do for the West Coast Multi Plex, but the charge-back is much higher than we would anticipate. As well, the Sechelt arena is an aging facility, built on volunteer labour to start with, and the maintenance costs of keeping it fully up to date, which they are doing, is significant.

The result is a deficit about 50 per cent higher than projected for the West Coast. We do not see a direct parallel between the two operational costs and feel this can be avoided on the West Coast.

Port McNeill

The Port McNeill arena is a busy rink, creating similar revenue to the West Coast but with rental rates between 58 and 80 per cent of the West Coast projection. It seems to be a well-run facility, but at a high staff level. Staffing is the primary cost difference, with overall cost almost double our projection. In fairness, these costs do include operating the adjoining curling club, which requires significant staff presence despite low revenues.

As well as two full operator shifts six days per week, the arena employs a programs/concession/office supervisor. The concession is a significant operation, but not a money-maker. The West Coast will simply not be able to provide the same level of public service within the foreseeable demand.

Aldergrove and Three Ontario Rinks

Aldergrove arena is designated as primarily a Minor Hockey arena, but higher youth rates and a packed schedule late into the evening keep revenue high. This Langley area also has the most successful ball hockey organization we are aware of, making dry floor use pay for the facility. With a full house throughout the year and an aggressive approach to concession revenue, Aldergrove is the one rink in our sampling able to operate food service on a truly profitable basis. Lower staff hourly costs keep expenses in line, resulting in a low operational deficit of \$175,000.

Collingwood, which is in our sample, and Cayuga and Dunnsville, Ontario, are all examples provided to show that a busy rink can be operated to provide more recreation without raising the operating deficit beyond what is about the minimum in the field. These three were among the lowest deficits we found at between \$141,000 and \$199,000.

Budget Comparisons - Rinks with Higher Cost Recovery

	West Coast	Port Hardy	Sechelt (1 of 2 arenas)	Aldergrove	Collingwood 1 of 2 arenas)	Cayauga ON	Dunnville ON
REVENUE							
Skate Rental and Sharpen	\$3,452	\$3,570	\$2,500	\$6,538	\$3,000		
Advertising, Sponsors	\$6,400	\$3,836	\$5,370	\$2,320	\$5,750	\$9,000	\$15,000
Vending (Net); & Other	\$1,500	\$1,377	\$1,000	\$27,412	\$4,200	\$2,000	\$6,000
Programs All						\$5,000	\$8,000
Ice Programs - Pub. Skate / Drop In	\$24,564	\$6,732	\$24,061	\$21,220	\$3,000		
Dry Floor Programs	\$1,650						
Ice Rental - All		\$72,420	\$133,158	\$218,868	\$290,000	\$173,000	\$202,000
Rental Ice - Youth	\$19,125						
Rental Ice - Adult	\$60,300						
Rental Ice - Other	\$3,300						
Rental Dry Events	\$1,500	\$3,672	\$10,700	\$20,319		\$1,000	\$2,000
Rental - Meeting or other			\$1,500	\$4,223		\$5,000	
Other Revenue							
TOTAL OPERATING REVENUE	\$121,791	\$91,607	\$178,289	\$300,900	\$305,950	\$195,000	\$233,000
ADMINISTRATION							
Administration	\$25,000		\$65,960	\$14,296			
Bank Charges	\$3,000		\$8,060	\$983			
Advertising	\$2,000		\$6,120	\$905			
Insurance	\$16,000	\$743	\$12,284	\$10,986	\$400		
Licences and Dues	\$2,500						
Office; Shipping	\$1,200		\$1,020	\$1,479			
Phones, Int. Alarm, Computer	\$3,000		\$8,459	\$5,014	\$1,200		
Total Administration	\$52,700	\$743	\$101,903	\$33,663	\$1,600		
SALARIES/WAGES/BENEFITS							
Management and Supervisors	\$40,000						
Ice Operators	\$108,339	\$173,400	\$298,461	\$237,637	\$255,656		
Program Staff	\$16,422	\$3,027	\$3,873	\$5,336	\$500		
Uniform (or Allowance)	\$800						
Training/Workshops/Seminars	\$3,500						
Total Wages, Benefits, Training	\$169,061	\$176,427	\$302,334	\$242,973	\$256,156		
UTILITIES							
Hydro; Propane; Nat Gas	\$60,000	\$47,800	\$53,021	\$87,325	\$162,110		
Water & Sewer; Garbage	\$6,000	\$5,202	\$7,100	\$19,281	\$7,000		
Total Utilities	\$66,000	\$53,002	\$60,121	\$106,606	\$169,110		
OPERATIONS							
Vehicle	\$5,000	\$-		\$4,120	\$2,850		
Safety	\$2,500	\$3,633	\$2,510	\$2,576	\$3,800		
Supplies & Materials	\$18,000	\$6,326	\$24,943	\$12,028	\$8,630		
Grounds and Parking	\$4,000	\$20,400	\$10,490				
Repairs & Maintenance	\$24,000	\$14,362	\$45,413	\$73,995	\$62,900		
Equipment Rentals	\$2,500						
Contract Labour	\$3,000						
Total Operations	\$59,000	\$44,721	\$83,356	\$92,719	\$78,180		
Total Operating Expense	\$346,761	\$274,893	\$547,714	\$475,961	\$505,046	\$336,000	\$400,000
Net Operating Surplus (Deficit)	-\$224,970	-\$183,286	-\$369,425	-\$175,061	-\$199,096	-\$141,000	-\$167,000
Cost Recovery on Operating	35%	33%	33%	63%	61%	58%	58%

Budget Comparisons - Rinks with Lower Cost Recovery

	West Coast	Port McNeill	Golden	Port Alice	Princeton	Port McNeill
REVENUE	\$3,452					
Skate Rental and Sharpen	\$6,400	\$-				
Advertising, Sponsors	\$1,500	\$3,400				\$7,000
Vending (Net); & Other						
Programs All	\$24,564	\$1,500				
Ice Programs - Pub. Skate and Drop In	\$1,650					
Dry Floor Programs		\$43,000				\$110,000
Ice Rental - All	\$19,125					
Rental Ice - Youth	\$60,300					
Rental Ice - Adult	\$3,300					
Rental Ice - Other	\$1,500					
Rental Dry Events		\$4,500				\$8,000
Rental - Meeting or other						\$11,800
Other Revenue						
Total Operating Revenue	\$121,791	\$52,400	\$60,120	\$13,000	\$74,460	\$136,800
ADMINISTRATION	\$25,000				\$14,600	\$23,700
Administration	\$3,000					
Bank Charges	\$2,000				\$1,020	
Advertising	\$16,000	\$10,500	\$10,227	\$15,500	\$17,918	\$10,000
Insurance	\$2,500					\$1,855
Licences and Dues	\$1,200	\$500		\$-		
Office; Shipping	\$3,000	\$3,500		\$1,800	\$4,187	\$5,000
Phones, Internet, Alarm, Computer	\$52,700	\$14,500	\$10,227	\$17,300	\$37,725	\$40,555
Total Administration						
SALARIES/WAGES/BENEFITS	\$40,000					
Management and Supervisors	\$108,339	\$195,500	\$255,681	\$123,000	\$259,622	\$354,274
Ice Operators	\$16,422	\$2,000	\$3,000	\$3,600		
Program Staff	\$800					
Uniform (or Allowance)	\$3,500					
Training/Workshops/Seminars	\$169,061	\$197,500	\$258,681	\$126,600	\$259,622	\$354,274
Total Wages, Benefits, Training						
UTILITIES	\$60,000	\$66,500	\$58,769	\$76,000	\$55,178	\$54,000
Hydro; Propane; Nat Gas	\$6,000				\$5,587	\$3,000
Water & Sewer; Garbage	\$66,000	\$66,500	\$58,769	\$76,000	\$60,765	\$57,000
Total Utilities						
OPERATIONS	\$5,000	\$2,300		\$-		
Vehicle	\$2,500					
Safety	\$18,000	\$24,100	\$36,000	\$-	\$8,100	\$8,000
Supplies & Materials	\$4,000	\$15,000	\$18,000			\$45,000
Grounds and Parking	\$24,000	\$13,000	\$48,700	\$41,000	\$36,530	\$25,000
Repairs & Maintenance	\$2,500					
Equipment Rentals	\$3,000					
Contract Labour	\$59,000	\$54,400	\$102,700	\$41,000	\$44,630	\$78,000
Total Operations						
Total Operating Expense	\$346,761	\$332,900	\$430,377	\$260,900	\$402,742	\$529,829
Net Operating Surplus (Deficit)	-\$224,970	-\$280,500	-\$370,257	-\$247,900	-\$328,282	-\$393,029
Cost Recovery on Operating	35%	16%	14%	5%	18%	26%

Future Aquatic Centre

Even though some communities smaller than the West Coast have aquatic centres, the communities considering building one today tend to have a similar or greater population. This is likely because there are now less small communities with resource economies and therefore industry carrying the tax load.

What differentiates successful aquatic centres from the rest is the ability to create and maintain public excitement around every day activities at the facility. A flexible operation, and programs created, promoted and delivered by innovative staff are essential. Creating a successful arena operation will be the first step to public acceptance of a next phase to the Multi Plex and generating excitement around the concept.

A general rule of thumb is that each component (ice, pool, fitness, library, etc.) added to a recreation facility improves the attendance at each by 10 per cent, as every area stays top-of-mind with participants of any one of the areas. There are also benefits in staffing efficiency and, with proper systems, energy efficiency. In spite of cross-efficiencies between the arena and pool areas, operating an aquatic centre is an expensive venture.

MELDING THE DESIGN

- The current arena lobby should be small and able to meld into a larger general lobby adjoining the two.
- Public Washrooms will need to be accessible when either the pool or the rink is closed but duplication may be avoided with locating washrooms in the lobby during Phase One.
- All possible energy efficiency programs become essential as using propane to heat the pool will be very expensive. Accessing arena heat recovery will be important.
- If the arena uses an ammonia system, and greater than 25kW per unit, there will be a need to create separate “buildings” to allow for the pool opening without a certified arena operator on site.
- The current design requires the existing parking lot to be used for the pool building platform. There should be some consideration of the long-term site servicing cost efficiencies prior to that plan being implemented.
- An arena mezzanine, if there is one, could become a fitness area, but there could be some complications around staffing at times during the ice season due to the need to have a certified staff on site.

OPERATIONS

- A pool will open and close earlier, creating potential for some morning and daytime ice use without always adding operations staff.
- There will likely be two new administrative positions: Manager and Full Time Clerical. Therefore, administration, bookings, program registration, billing, etc. would all move on-site efficiently.
- Flexibility in staffing arrangements and the hourly cost of reception and lifeguarding staff are vitally important in cost recovery of an aquatic centre.

Notes

Appendix - Arena Floor Plans

CAYUGA ONTARIO ARENA 2012

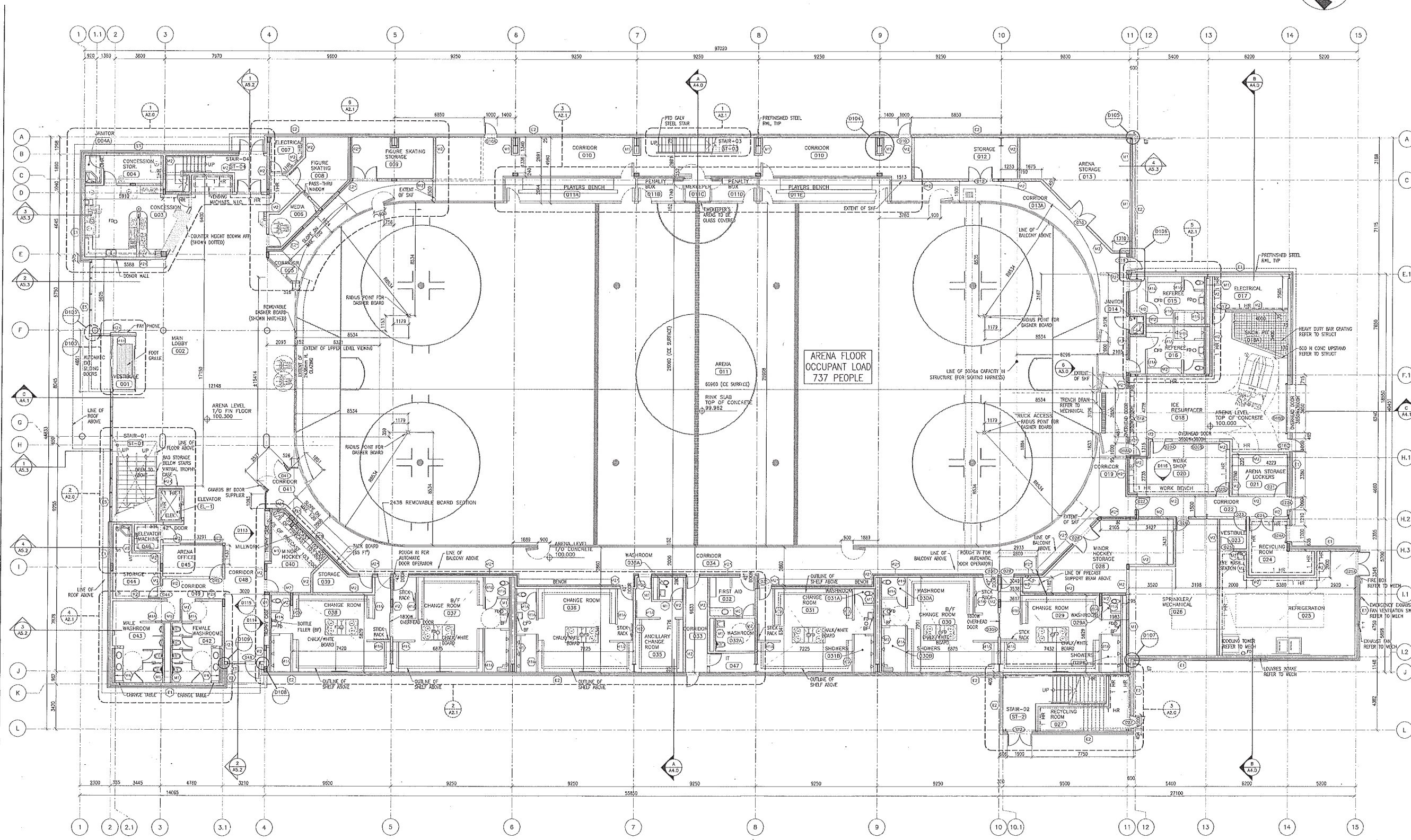
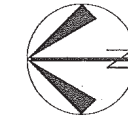

AREA = 3668 m²
= 39482 ft²

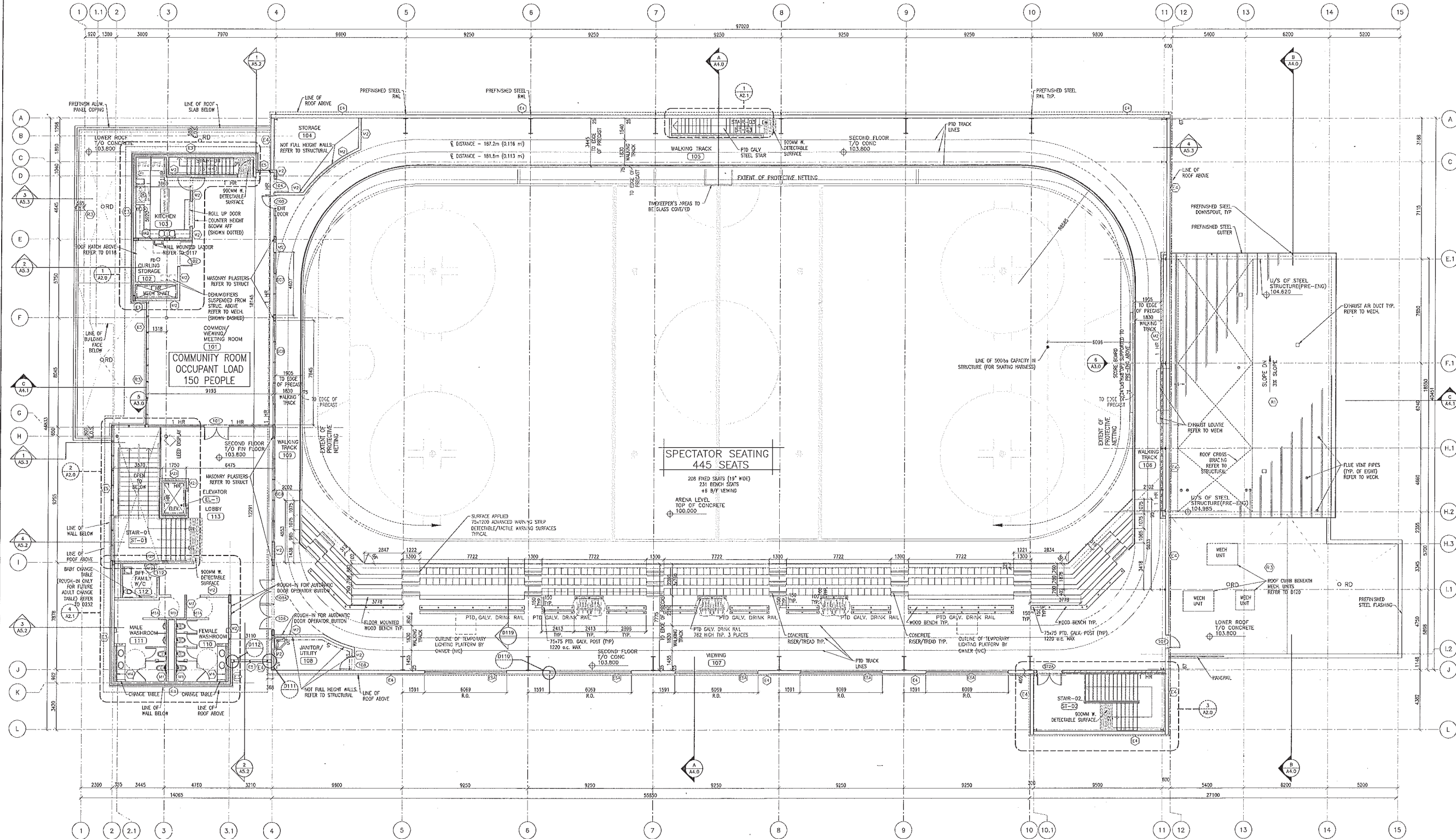
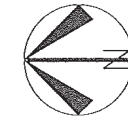

AREA = 1456 m²
= 15677 ft²

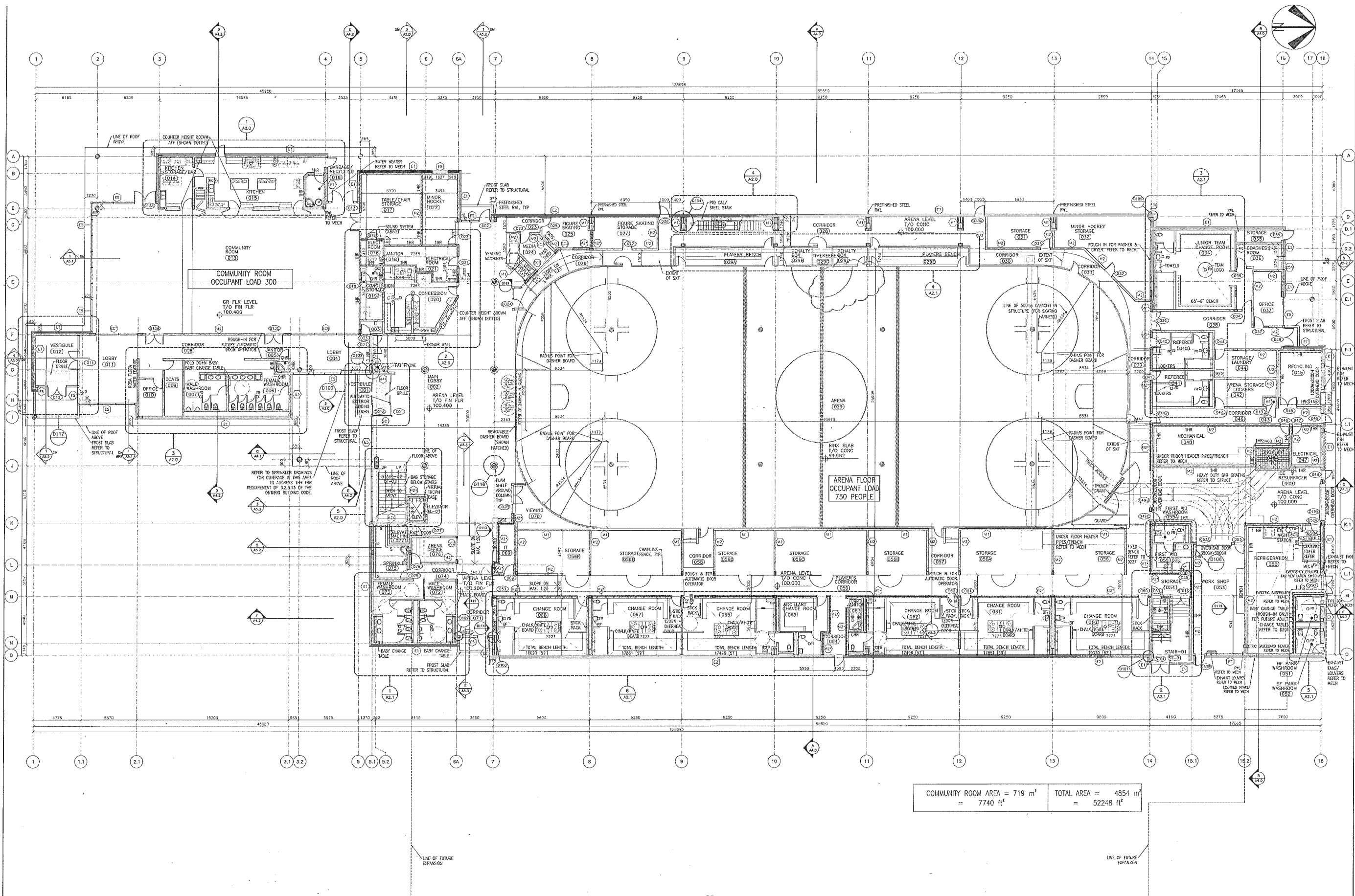

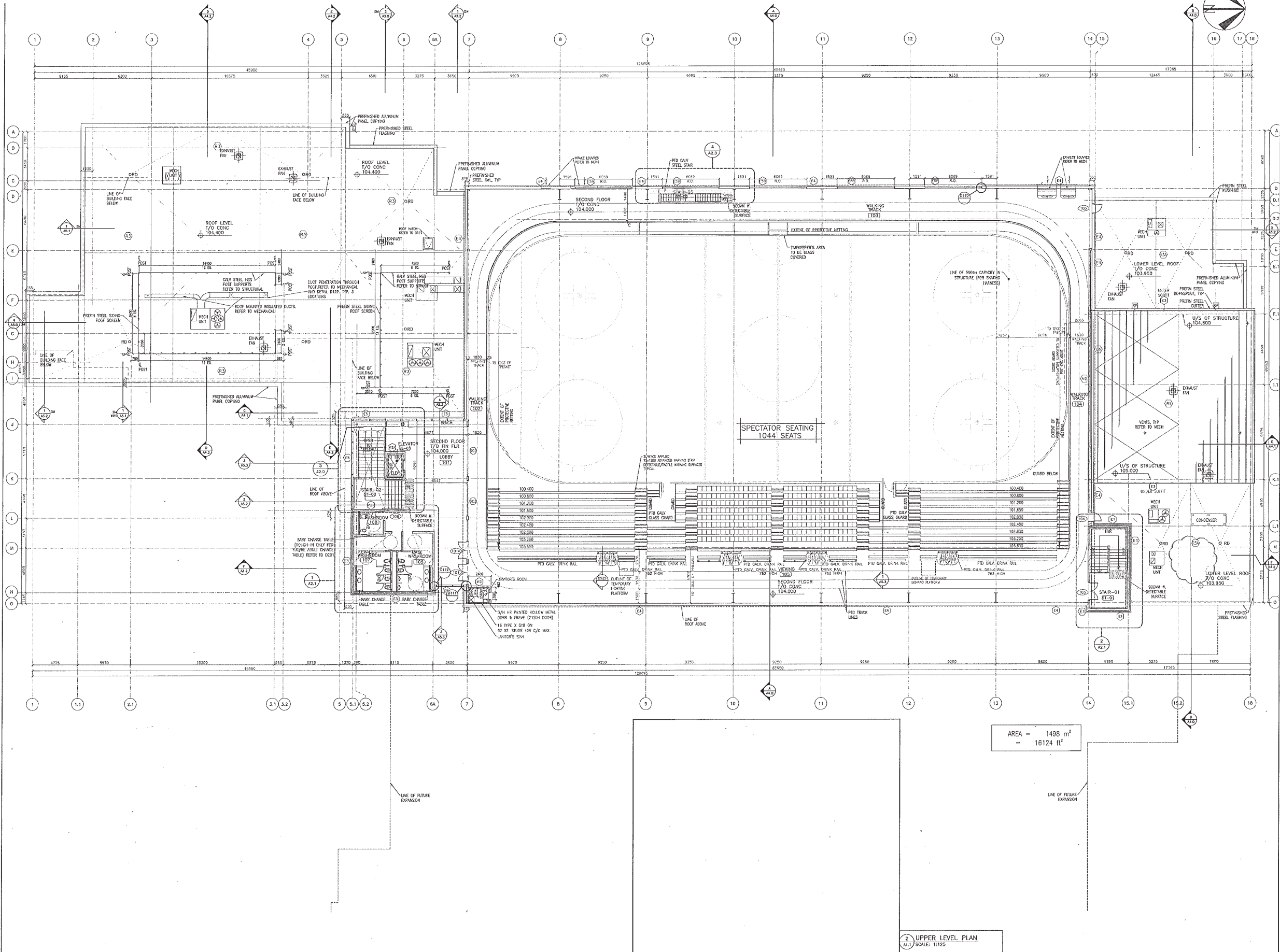

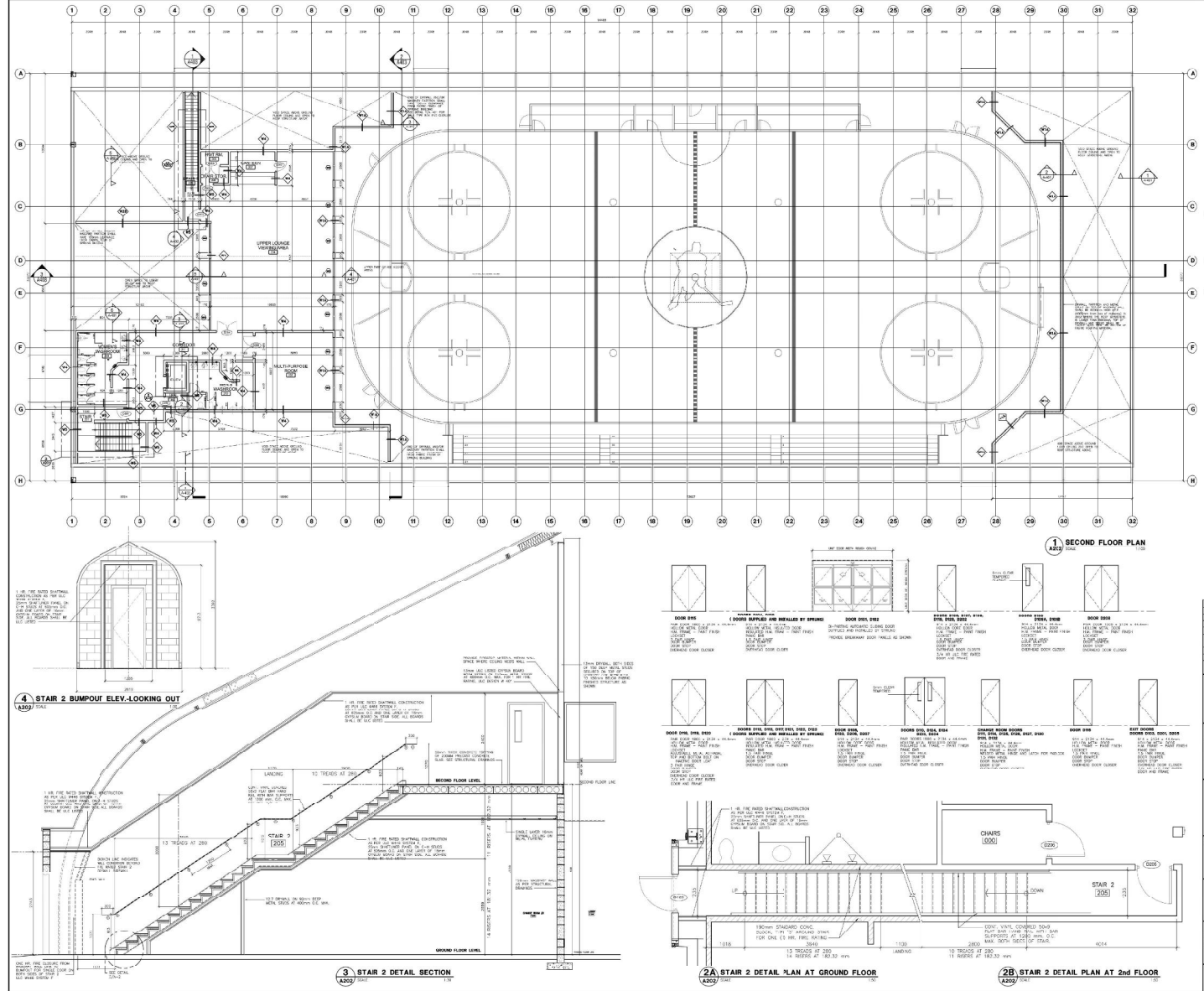
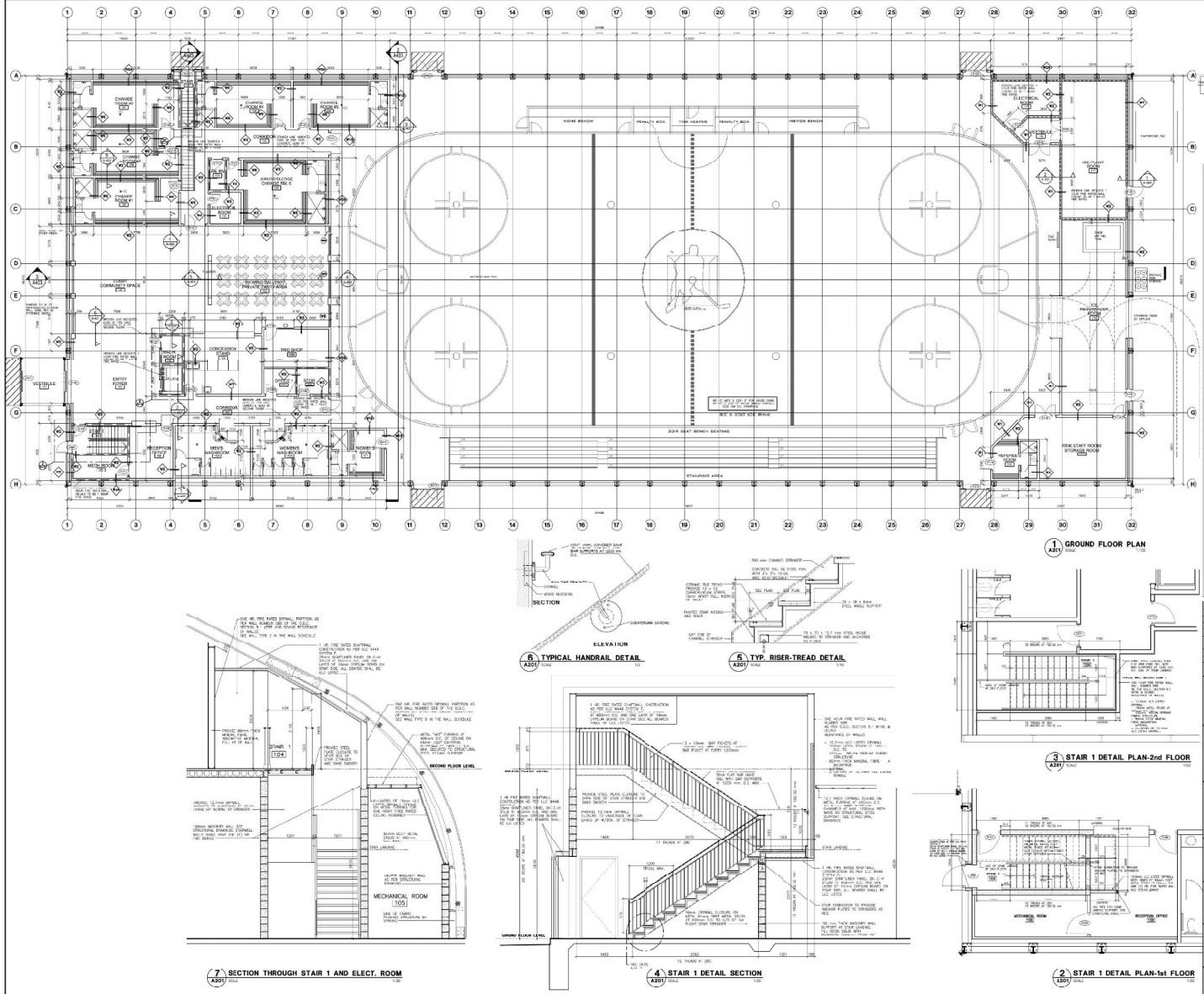

SHAWNIGAN LAKE (SPRUNG STRUCTURE) ARENA 2015

100584

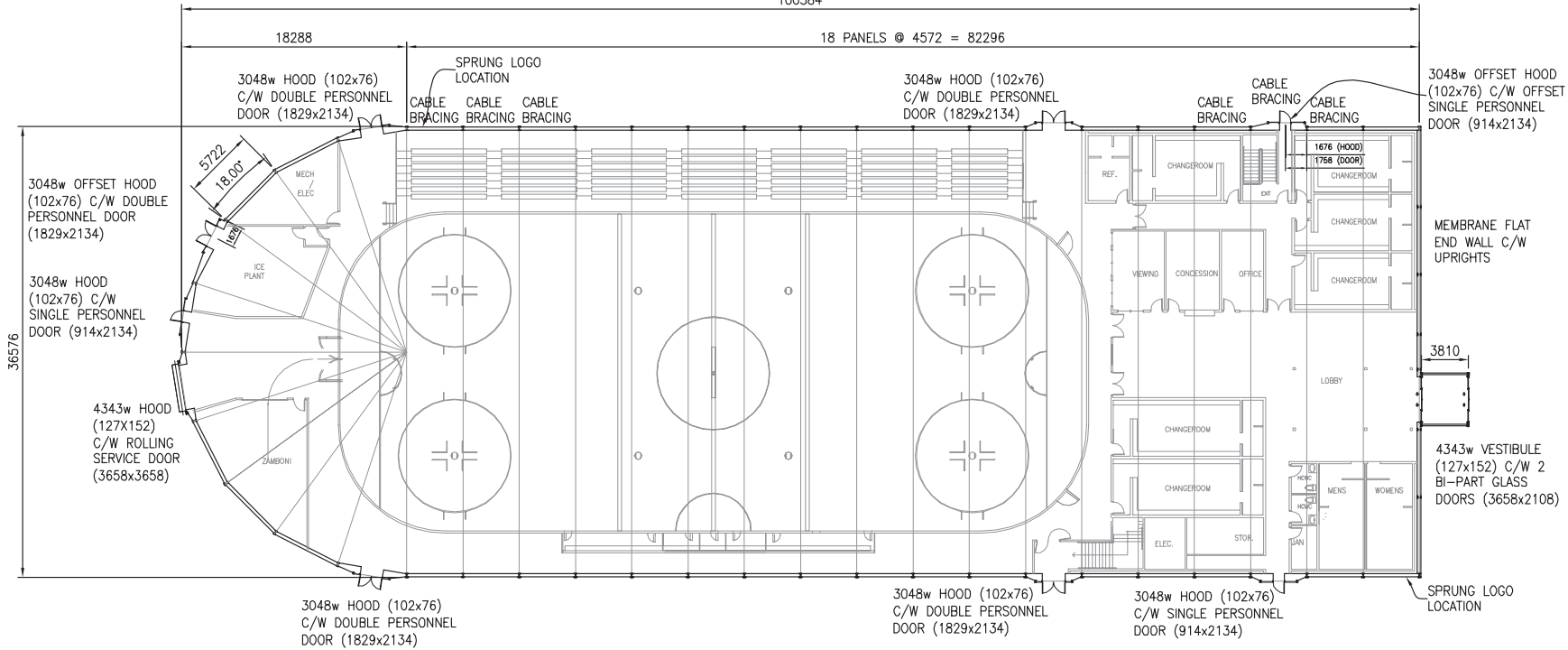

1 OPEN PLAN VIEW
043.0 1:250

INTERIOR SHOWN FOR REFERENCE ONLY, FINAL LAYOUT DESIGNED & SUPPLIED BY OTHERS.

COLORS ON THESE ELEVATIONS MAY VARY SIGNIFICANTLY DEPENDING ON PRINTER OR MONITOR. PLEASE REFER TO MEMBRANE SAMPLES FOR ACTUAL COLORS.

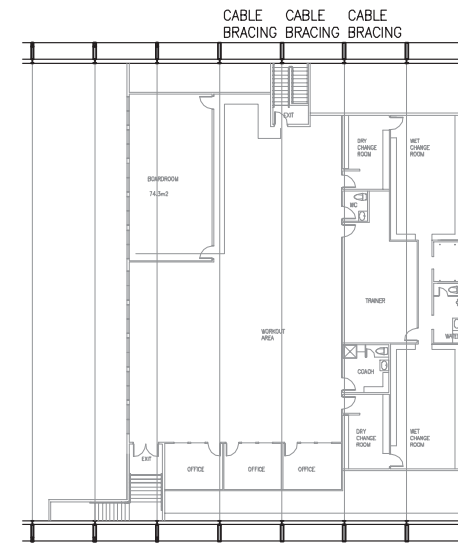

5 MEZZANINE PLAN VIEW
043.0 1:250

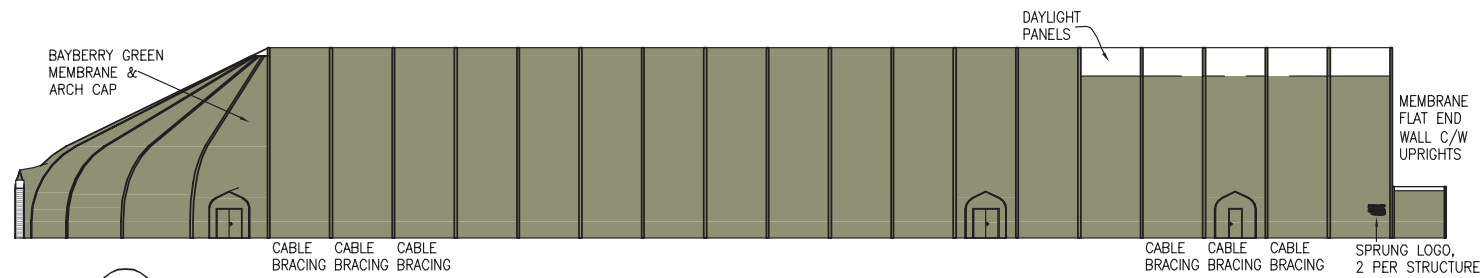

2 ELEVATION
043.0 1:250

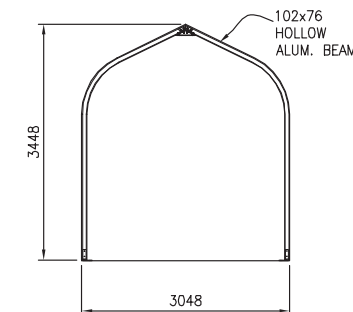

6 SECTION 3.0m HOOD
043.0 1:00

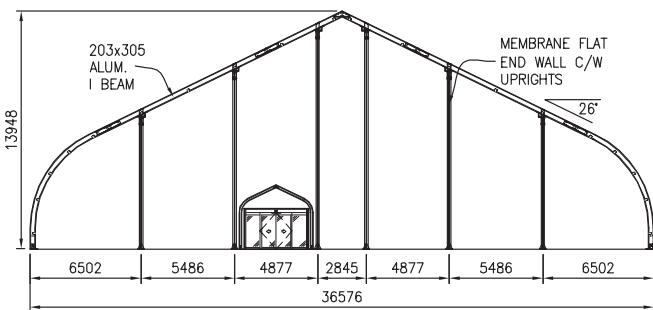

3 FLAT END 36.6m STRUCTURE
043.0 1:200

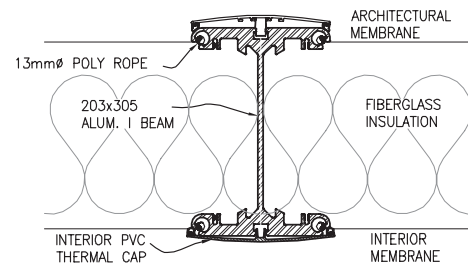

4 203x305 INSULATED BEAM SECTION
043.0 1:5

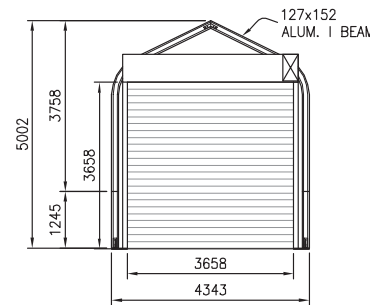

7 4.3m HOOD C/W 1245 LEG
043.0 1:75

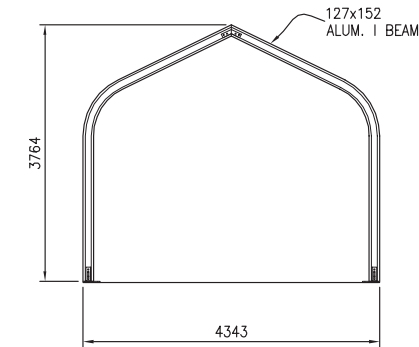

8 SECTION 4.3m HOOD
043.0 1:100



innovation | versatility | reliability

TOLL FREE: 1-800-528-9899
OR (403) 245-3371 www.sprung.com

GENERAL NOTES:

- ALL PERSONNEL DOORS C/W PANIC HARDWARE & HOODS.
- STRUCTURE TO BE INSULATED WITH FIBERGLASS BATT INSULATION C/W INNER LINER, TO DAYLIGHT PANELS.
- INNER & OUTER MEMBRANE TO BE FINISHED TO CONCRETE USING ALUM. FLAT BAR
- STRUCTURE MEMBRANE MEETS: NFPA 701, CALIFORNIA STATE FIRE MARSHAL, ASTM E84, ULCS109, & ULCS102 SPECIFICATIONS
- THIS STRUCTURE IS DESIGNED TO SHED SNOW. THE PERIMETER OF THE STRUCTURE SHOULD BE KEPT CLEAR.
- WHEN DESIGNING A HEATING, VENTILATION OR AIR CONDITIONING SYSTEM FOR ANY TYPE OF BUILDING, IT IS IMPORTANT TO ENSURE THAT THIS SYSTEM INTAKES MORE AIR THAN IS BEING EXHAUSTED AT ANY GIVEN TIME. THIS PROCESS WILL RESULT IN A POSITIVE PRESSURE BEING MAINTAINED. CONVERSELY, IF NEGATIVE PRESSURE EXISTS WITHIN THE STRUCTURE, IT WILL BE DIFFICULT TO OPEN DOORS AND MOISTURE WILL BE DRAWN INTO THE STRUCTURE.
- ALL INTERIOR WALLS & PARTITIONS (IF APPLICABLE) TO BE FREE STANDING & INDEPENDENT OF SPRUNG STRUCTURE.

DESIGN LOADS

STRUCTURE LOCATION: SHAWNIGAN LAKE, BC
BUILDING CODE: BCBC/NBC
WIND PRESSURE (q50): 0.39 kPa
GROUND SNOW LOAD:
Ss: 2.4 kPa
Sr: 0.3 kPa

SIGNATURE SERIES

REV.	DATE	DESCRIPTION
8	07/23/14	REVISE CB LAYOUT
7	07/21/14	ADD BI-PART DOOR TO VEST
6	07/09/14	MODIFY MEZZANINE LAYOUT
5	07/09/14	ADD NEW INTERIOR LAYOUT
4	07/07/14	OFFSET CENTER HOOD
3	06/23/14	ADD SPD & COLOR
2	02/06/14	CHANGE INTERIOR LAYOUT & REMOVE BAY

This drawing is protected by copyright in the United States of America, Canada and all other countries of the world. It and all of the designs, technical data and engineering services represented by it and originated or rendered by SPRUNG INSTANT STRUCTURES INC. are the exclusive property of SPRUNG INSTANT STRUCTURES INC. and must not be used in manufacturing nor disclosed nor reproduced in whole or in part except with the prior written consent of SPRUNG INSTANT STRUCTURES INC. Any copying of this drawing in whole or in part and any use of it to construct the subject matter illustrated in it without prior written permission of SPRUNG INSTANT STRUCTURES INC. is prohibited.

SHAWNIGAN LAKE SCHOOL

36.6m x 100.6m
ARENA

DRAWN	M. HILLIS	DATE	02/04/2014
CHECKED		APP'D	
SCALE	AS NOTED	DRAWING #	
CUST. APPL.			P14-043.0

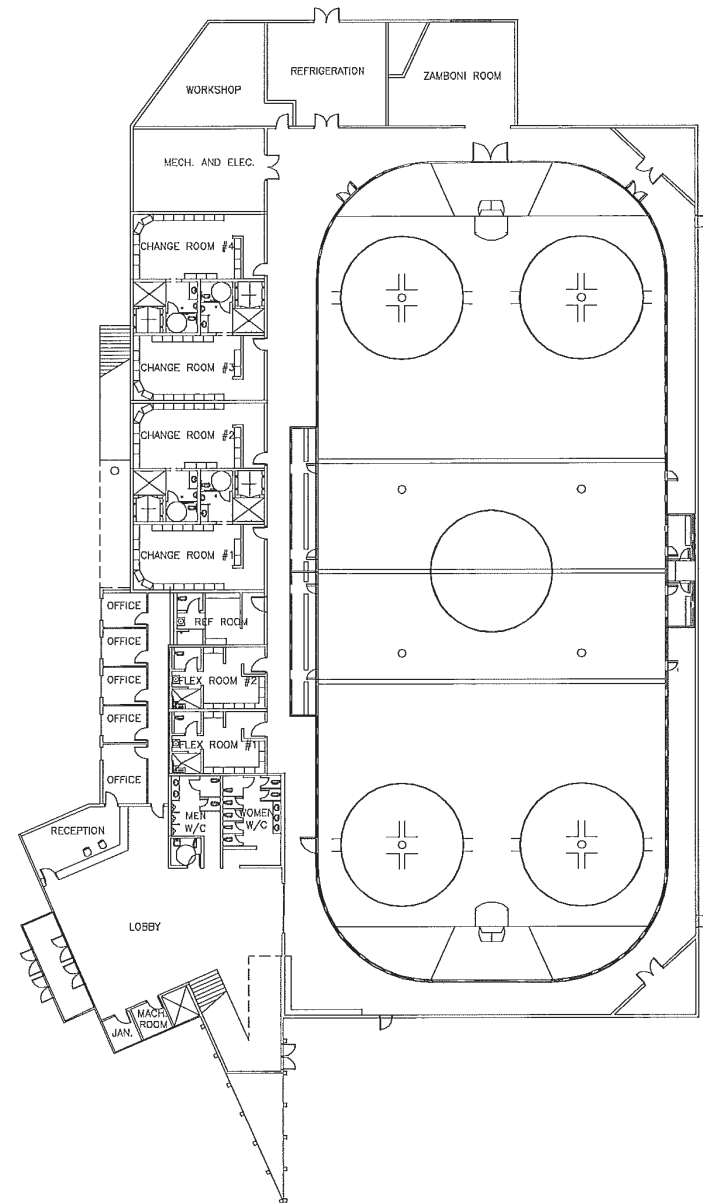

FIRST FLOOR

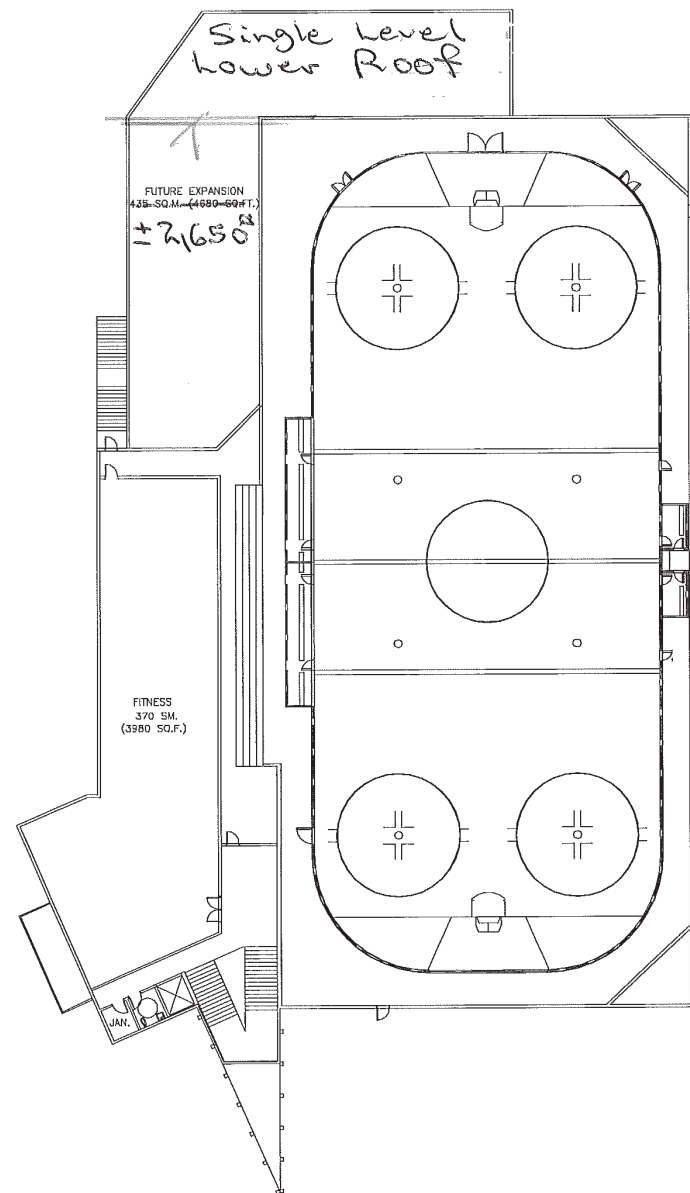

SECOND FLOOR

First Floor: 34,445 sq. ft.

Second Floor: 6300 sq. ft.

• VVI = 6900 sq ft.

Total: 40,745 sq. ft.

• VVI = 46,345 sq ft.

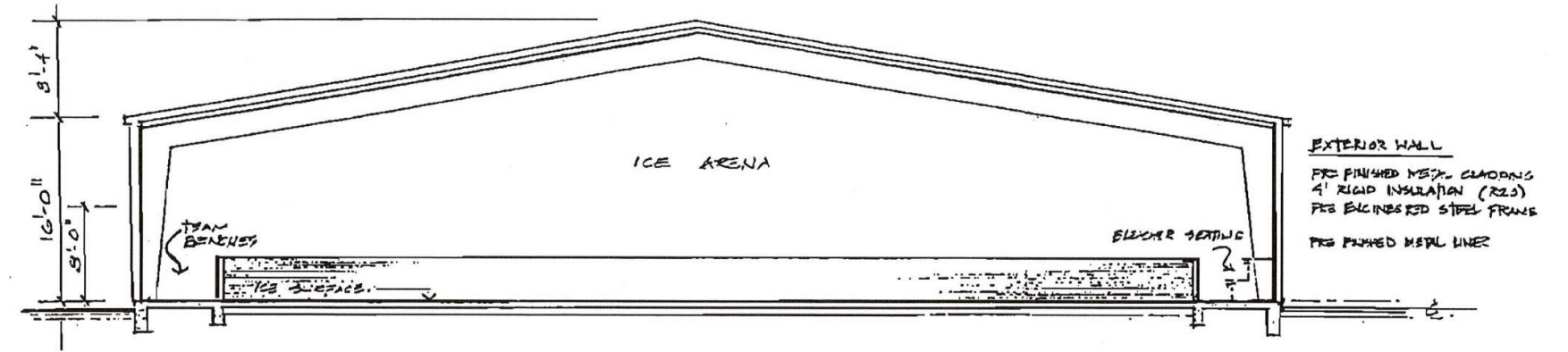
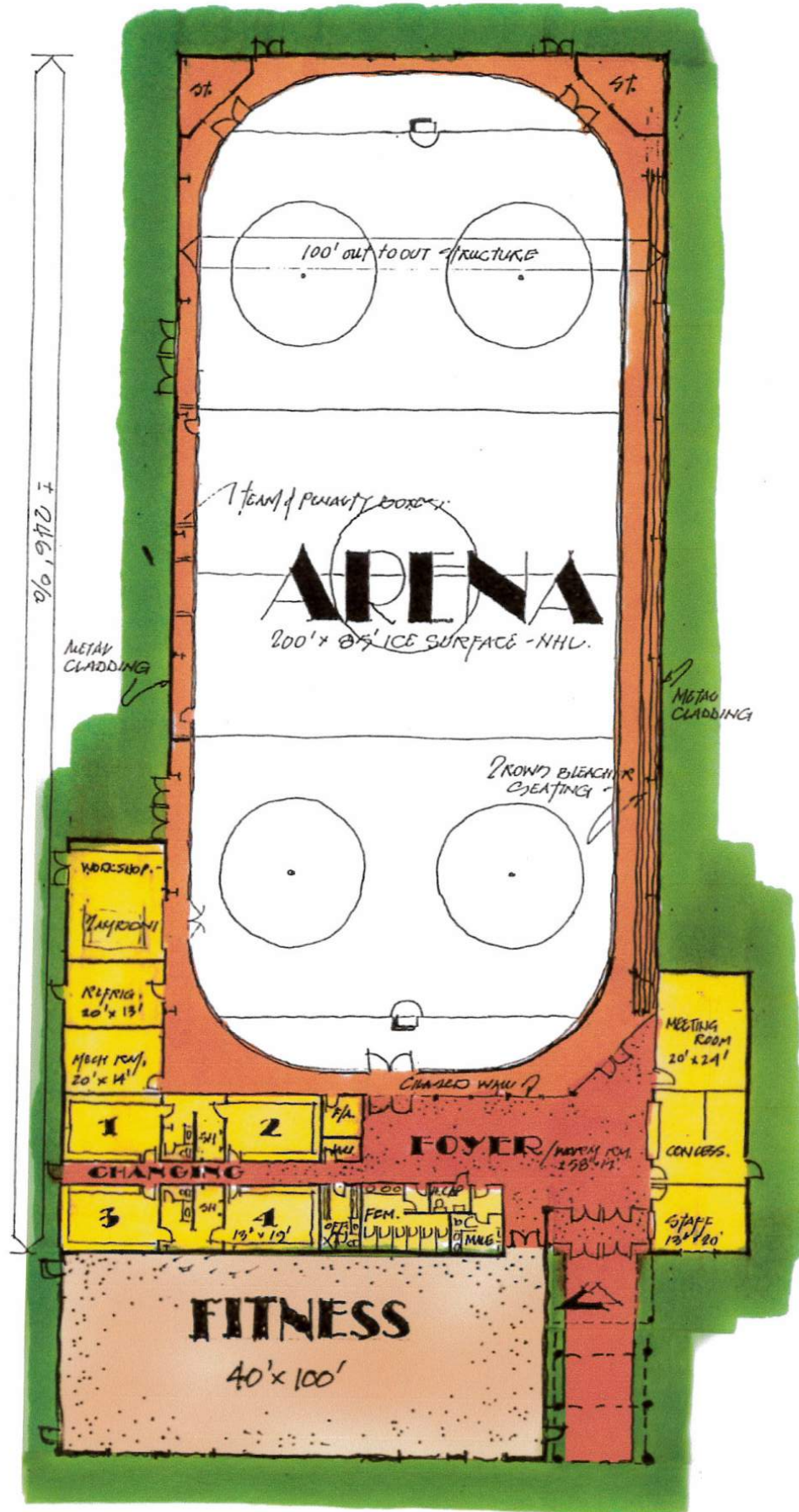

BUILDING SECTION 1

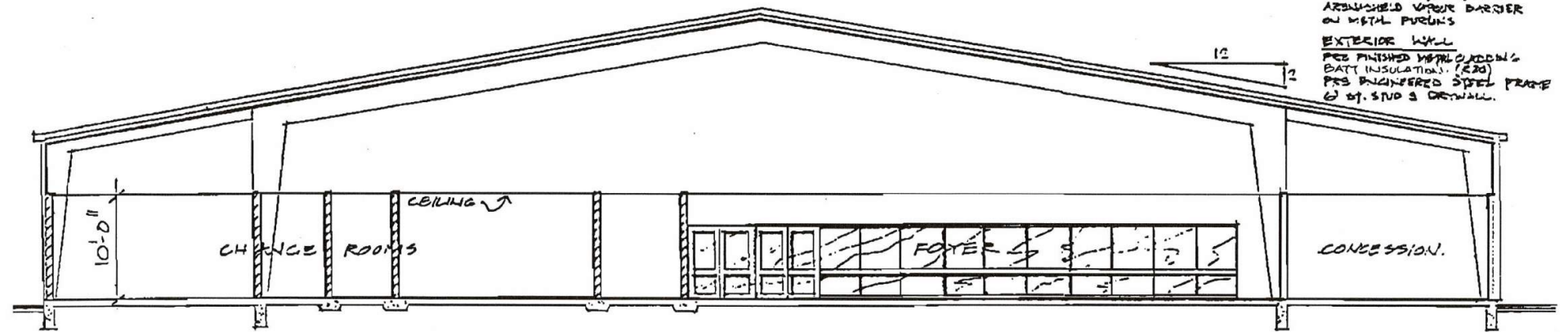

BUILDING SECTION 2



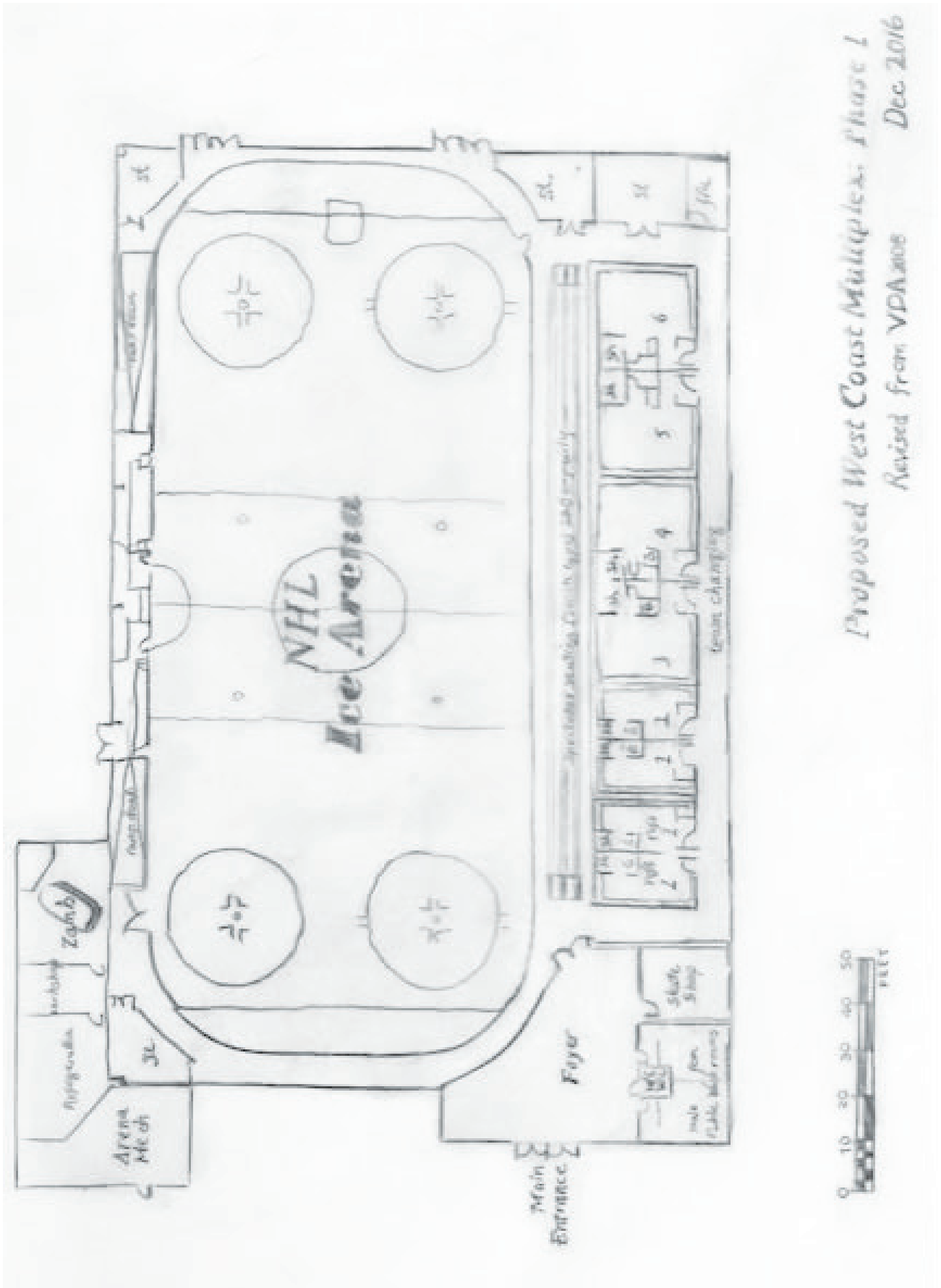

Proposed West Coast Multiplex, Phase 1
 Revised from VDA 2008 Dec 2016



MEMORANDUM

To: West Coast Committee
From: Teri Fong, CPA, CGA, Manager of Finance
Date: January 26, 2017
Subject: West Coast Multiplex 2016 Expenditures

The 2016 expenditures for the West Coast Multiplex were as follows:

Contribution From	Amount	Expenditures	Surplus for 2017
ACRD	\$20,000.00	\$9,823.36	\$10,176.64
Tla-o-qui-aht	\$100,000.00	\$18,437.50	\$81,562.50
Total	\$120,000.00	\$28,260.86	\$91,739.14

The Alberni-Clayoquot Regional District expenditures include the consulting services of Scott Kenny and some engineering work for site servicing. The Tla-o-qui-aht expenditures include the feasibility report and business plan prepared by Rec Excellence.