



Alberni-Clayoquot Regional Hospital District

BOARD OF DIRECTORS MEETING

WEDNESDAY, MAY 11, 2016

Regional District Board Room, 3008 Fifth Avenue, Port Alberni, BC

AGENDA

	PAGE #
1. <u>CALL TO ORDER</u> <i>(immediately following the ACRD Board Meeting)</i>	
Recognition of Traditional Territories.	
2. <u>APPROVAL OF AGENDA</u> <i>(motion to approve, including late items requires 2/3 majority vote)</i>	
3. <u>ADOPTION OF MINUTES</u>	
a. Board of Directors Meeting - April 13, 2016	3-5
<i>THAT the minutes of the Alberni-Clayoquot Regional Hospital District Board of Directors held on April 13, 2016 be adopted.</i>	
4. <u>PETITIONS, DELEGATIONS & PRESENTATIONS (10 minute maximum)</u>	
5. <u>CORRESPONDENCE FOR ACTION</u>	
6. <u>CORRESPONDENCE FOR INFORMATION</u>	
a. Correspondence dated April 19, 2016 from Capital Planning, Island Health regarding Tofino General Hospital Helipad Update.	6-8
b. Correspondence dated April 20, 2016 from Island Health regarding response to Critical Bed Shortage at West Coast General Hospital.	9-10
<i>THAT this correspondence be received for information.</i>	
7. <u>REQUEST FOR DECISIONS & BYLAWS</u>	
a. Request for Decision Finance Warrant No. 487	11-12
<i>THAT the Alberni-Clayoquot Regional Hospital District Board of Directors approves Finance Warrant Number 487 in the amount of \$453,658.98 dated April 30, 2016.</i>	

8. REPORTS

- a. Bamfield Health Centre – K. Wyton
- b. Alberni-Clayoquot Continuing Care Society – J. McNabb
- c. Island Health Capital Planning Committee – P. Cote
- d. West Coast Native Health Care Society – P. Cote
- e. Tofino General Hospital – J. Osborne/D. St. Jacques
- f. Alberni-Clayoquot Health Network – P. Cote/M. Ruttan
- g. Other Reports

THAT the Regional Hospital Board of Directors receives reports a-g.

9. UNFINISHED BUSINESS

10. LATE BUSINESS

11. QUESTION PERIOD

12. ADJOURN



Alberni-Clayoquot Regional Hospital District

MINUTES OF THE BOARD OF DIRECTORS MEETING HELD ON WEDNESDAY, APRIL 13, 2016

Regional District Board Room, 3008 Fifth Avenue, Port Alberni, BC

DIRECTORS

PRESENT:

Penny Cote, Chairperson, Electoral Area "D" (Sproat Lake)
Josie Osborne, Vice-Chairperson, Mayor, District of Tofino
Keith Wyton, Electoral Area "A" (Bamfield)
Mike Kokura, Electoral Area "B" (Beaufort)
Tony Bennett, Electoral Area "C" (Long Beach) (via teleconference)
John McNabb, Electoral Area "E" (Beaver Creek)
Lucas Banton, Electoral Area "F" (Cherry Creek)
John Jack, Councillor, Huu-ay-aht First Nation
Jack McLeman, Councillor, City of Port Alberni
Mike Ruttan, Mayor, City of Port Alberni
Dianne St. Jacques, Mayor, District of Ucluelet
Alan McCarthy, Member of Legislature, YuułuꞀiꞀꞀath Government
Wilfred Cootes, Councillor, Uchucklesaht Tribe Government

STAFF PRESENT:

Russell Dyson, Chief Administrative Officer
Andrew McGifford, Manager of Environmental Services
Teri Fong, Manager of Finance
Mike Irg, Manager of Planning and Development
Wendy Thomson, Manager of Administrative Services

1. CALL TO ORDER

The Chairperson called the meeting to order at 2:37 pm.

2. APPROVAL OF AGENDA

MOVED: Director Kokura

SECONDED: Director Osborne

THAT the agenda be approved as circulated.

CARRIED

3. ADOPTION OF MINUTES

a. Board of Directors Meeting - March 9, 2016

MOVED: Director St. Jacques

SECONDED: Director McLeman

THAT the minutes of the Alberni-Clayoquot Regional Hospital District meeting held on March 9, 2016 be adopted.

CARRIED

4. PETITIONS, DELEGATIONS & PRESENTATIONS

5. CORRESPONDENCE FOR ACTION

6. CORRESPONDENCE FOR INFORMATION

7. REQUEST FOR DECISIONS & BYLAWS

a. Request for Decision regarding Finance Warrant No. 486.

MOVED: Director Ruttan

SECONDED: Director Jack

THAT the Alberni-Clayoquot Regional Hospital District Board of Directors approves Finance Warrant Number 486 in the amount of \$123,440.07 dated March 31, 2016.

CARRIED

8. REPORTS

a. Bamfield Health Centre – K. Wyton

Director Wyton provided an update on the Bamfield helipad issue. He reported on a recent conference call with Mr. Chris Sullivan, Island Health Capital Planning. Island Health is contemplating two locations for the helipad recommended by the Consultant. A floating facility in front of the Bamfield Health Centre or the old Bamfield airport lands which are now owned by the Huu-ay-aht First Nation.

b. Alberni-Clayoquot Continuing Care Society – J. McNabb

Director McNabb reported the Society has a meeting in two weeks. They continue to fundraise for a new bus. \$109,000 has been raised to date. They will need to raise an estimated total of \$140,000.

c. IH Capital Planning Committee – P. Cote - No Report

d. West Coast Native Health Care Society – P. Cote - No Report

e. Tofino General Hospital – J. Osborne/D. St. Jacques

Director Osborne provided a brief update on the West Coast helipad issue.

f. Alberni-Clayoquot Health Network – P. Cote/M. Ruttan

Director Cote provided an update on the Alberni-Clayoquot Health Network. The contract with the Health Network Coordinator Marcie DeWitt has been extended for two years.

g. Other Reports – None

MOVED: Director McNabb

SECONDED: Director McLeman

THAT the Regional Hospital Board of Directors receives reports a-g.

CARRIED

9. UNFINISHED BUSINESS

10. LATE BUSINESS

MOVED: Director Wyton

SECONDED: Director St. Jacques

THAT the Alberni-Clayoquot Regional Hospital District Board of Directors write a letter to Island Health stressing the importance of the new helipad being located at the Bamfield Health Centre.

CARRIED

11. QUESTION PERIOD

12. ADJOURN

MOVED: Director McNabb

SECONDED: Director McLeman

THAT this meeting be adjourned at 2:55 pm.

CARRIED

Certified Correct:

Penny Cote,
Chairperson

Russell Dyson,
Chief Administrative Officer

April 19, 2016

Ref # 17497

Dianne St. Jacques
Chairperson, West Coast Committee
Alberni-Clayoquot Regional District
3008 5th Avenue
Port Alberni BC V9Y 2E3

Dear Ms. St. Jacques:

Re: Tofino General Hospital (TGH) Helipad: Update

Island Health's commitment to finding a solution to the TGH helipad is still ongoing.

As you may know, the TGH helipad was constructed in 1988 and certified under the Transport Canada heliport standards at the time. In 2010, the heliport was closed due to a number of deficiencies identified by Transport Canada. Since the closure, the airport has been used which is not ideal with the main reasons being the length of distance/time from the hospital and the occasional need to deploy TGH clinical staff to accompany the patient in the ground ambulance.

Over the past few years, various heliport options close to the hospital have been reviewed with each option having its pros/cons and complexities, making a decision very difficult.

To help with this challenge, Island Health recently retained consultants to summarize the previous review work and options, and make a recommendation to Island Health. The consultant's report recommended option 3 from the following options. Attachment 1 illustrates the location of these options.

1. Elevated steel helicopter platform at (not on) Hospital roof level.
 - a. Concerns with this option are:
 - i. it restricts natural light to the hospital and has serious noise impact;
 - ii. the existing hospital does not meet current seismic standards for roof or heightened elevator shaft and will require upgrading;
 - iii. the existing elevator is not properly sized to accommodate stretcher and BC Ambulance and TGH staff;
 - iv. it requires topping of trees on site and neighbouring sites, and removal of trees on adjacent road allowance; and
 - v. this is the most expensive option.

2. Elevated steel helicopter platform at (not on) Hospital roof level on First Street.
 - a. Concerns with this option are:
 - i. requires ramp to First Street, with access then down Neill Street to the hospital entrance;
 - ii. requires Hydro power line relocated underground;
 - iii. the close proximity to adjacent commercial and residential properties;

.../2

- iv. the concept requires further development to determine heliport classification;
 - v. requires topping of trees on neighbouring sites, and removal of trees on TGH and Foundation site; and
 - vi. this is the second most expensive option.
3. At grade, enlarged pad on old helipad location (Foundation and Island Health property).
- a. Concerns with this option are:
 - i. the Foundation property is not available as it has been leased to a non-profit society;
 - ii. a heliport at this location would limit future building location and height on Foundation property; and
 - iii. requires topping of trees on neighbouring sites, and removal of trees on adjacent road allowance.
4. At grade, located at shoreline (Foundation property).
- a. Concerns with this options are:
 - i. the Foundation property is not available as it has been leased to a non-profit society;
 - ii. a heliport at this location would limit future building location and height on Foundation property;
 - iii. requires less topping of trees on neighbouring sites, and removal of trees on adjacent road allowance;
 - iv. requires further geotechnical study as soil conditions indicate the area may have been used as log dump; and
 - v. a ground ambulance transfer would be required.

A replacement site for a new TGH facility has not been considered in this analysis as it is unlikely to proceed in the foreseeable future.

Island Health supports the consultant's recommendation of option 3, which, as mentioned, is subject to Island Health using the Foundation property. This option best meets the clinical and operational needs and is cost effective. As construction on the Foundation property has not started, Island Health will request an update from the Foundation on the timing of the non-profit society project and whether the property may be available for a helipad.

Please call me at (250) 370-8912 if you have any questions.

Yours truly,



Chris Sullivan
Director, Capital Planning

Attachment 1: Tofino General Hospital Heliports – Option 1 to 4

cc: Alberni Clayoquot Regional District, West Coast Committee
Marie Duperreault, Director, Port Alberni/West Coast
Kathryn Kilpatrick, Rural Site Director, West Coast

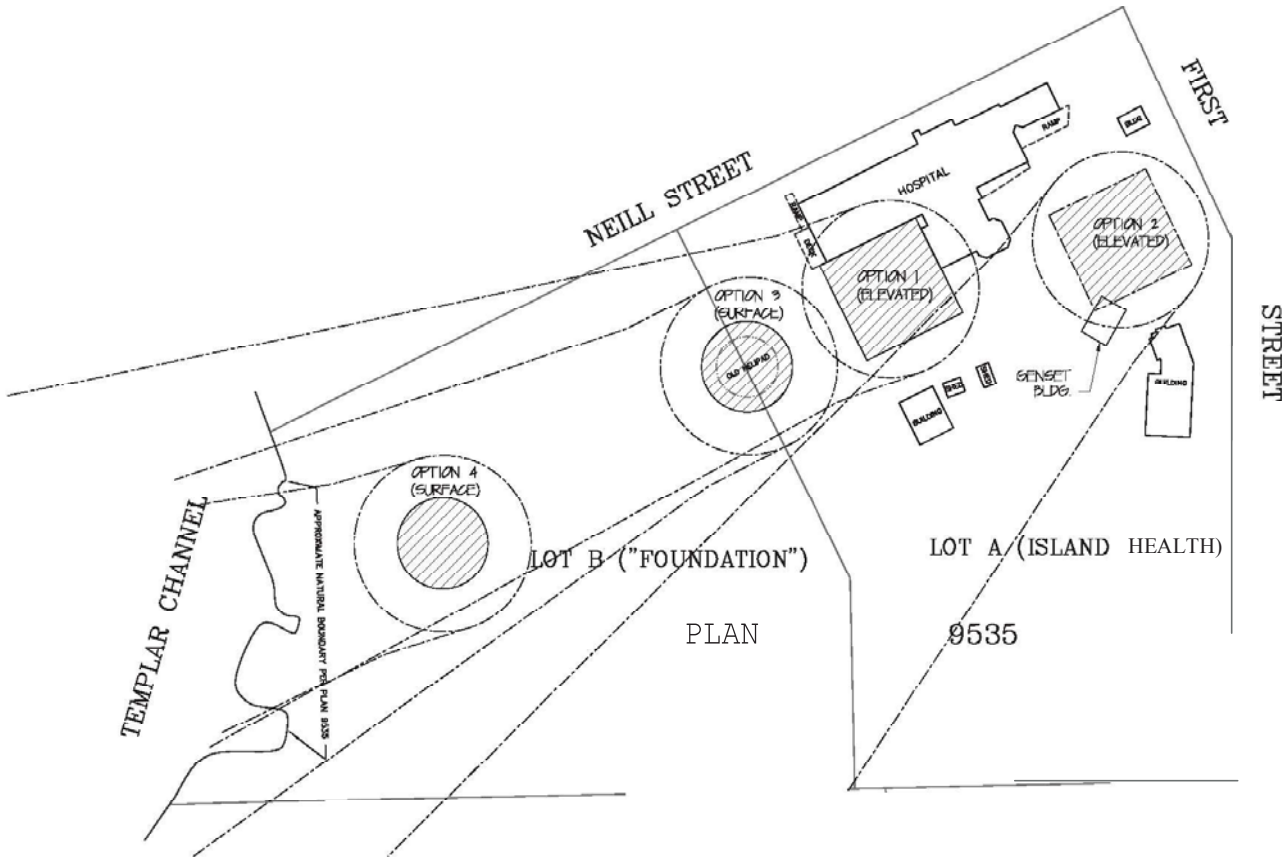

LOT 2

PLAN

21590

LOT 1



HELIPORTS - OPTION 1 TO 4

THIS DRAWING IS A PRELIMINARY AND NOT FULLY
 REPRESENTATIVE TO TRANSPIRE CANADA STANDARDS.

ir isBilitout
 Architecture Inc.
 111111111111111111
 222222222222222222
 333333333333333333
 444444444444444444
 www.irlt.com

TOFINO GENERAL HOSPITAL HELIPORT

HELIPORTS OPTION 1&OPTION2 OPTION3&OPTION4

ISSUED FOR: DRAWING NO:

April 20, 2016

Ms. Penny Cote
Chairperson
Alberni-Clayoquot Regional Hospital District
3008 Fifth Avenue
Port Alberni, BC
V9Y 2E3

Dear Ms. Cote,

Thank you for your letter dated April 7, 2016 regarding the Critical Bed Shortage at West Coast General Hospital within Island Health.

In your letter, you refer to a concern brought forward to the Alberni-Clayoquot Regional District by community member Mr. Frank Kruks. The concern stemmed from Mr. Kruks recent hospital stay and the issue of being relocated numerous times during his stay into areas that he summarized as being inappropriate.

I have had the opportunity meet with Mr. Kruks in person to discuss his recent experience. I acknowledge that various bed relocations into our patient overflow areas during Mr. Kruks stay was less than ideal, and this is a challenge that we have in meeting our surge capacity from time to time. This situation is not unique to West Coast General Hospital as all of our hospitals experience overcapacity situations, as do all hospitals across the country.

Temporary flow-through spaces are designated in each of our hospitals for such circumstances as well as to provide short-term rapid access so we can bring patients out of the emergency departments. We are very mindful of which patients are placed in overflow areas, and we do our very best to ensure that only patients who are mobile are placed in these areas. The current leadership for the Alberni-Clayoquot region of Geography 2, including the team at West Coast General Hospital, is reviewing overcapacity challenges locally as well as island wide with other organizational leadership.

Currently, there are seven people admitted to WCGH who are awaiting placement in residential care. This number changes constantly and is based on many contributing factors. As you know, we are currently working to develop a more robust system of care that will change the way we deliver community care and that will support seniors to stay in their own homes as long as they are able.

We will be happy to provide the information that you have requested and look forward to meeting with you to discuss your concerns and explore ways to work together to meet our community needs.

Thank you for taking the time to write to us about your concerns

Sincerely,



Pam Rardon RN BScN, MPH
Site Director, West Coast General Hospital

Cc: Dr. Brendan Carr, President and CEO, Island Health
Dr. Hassleback, Medical Health Officer, Island Health
Marie Duperreault, Director, Pt. Alberni/West Coast
Dr. Wendy Johnsen, Medical Director, Port Alberni/West Coast
Mr. Frank Kruks, Port Alberni Resident

REQUEST FOR DECISION

TO: Regional Hospital District Board of Directors
FROM: Teri Fong CPA, CGA, Manager of Finance
DATE: May 4, 2016
RE: Finance Warrant No.487

Recommendation:

THAT the Alberni-Clayoquot Regional Hospital District Board of Directors approves Finance Warrant Number 487 in the amount of \$453,658.98 dated April 30, 2016.

Chief Administrative Officer Comments:

Concur

IMPLICATIONS OF THE RECOMMENDATION

1. GENERAL

That the Regional Hospital District Board of Directors reviews the details of the expenditures made in the previous month and when satisfied, approves the finance warrant.

2. TIME REQUIREMENT – STAFF AND ELECTED OFFICIALS – none

3. FINANCIAL – none

4. POLICY OR LEGISLATIVE – none

5. RELEVANCE TO THE STRATEGIC PLAN AND CURRENT WORK PLAN

Improve financial controls by increasing the transparency of the Regional District's financial affairs.

6. COMMUNICATIONS ISSUES - none

Submitted by: Teri Fong, CPA CGA, Manager of Finance



**Alberni-Clayoquot Regional Hospital
Cheque Register - Detail - Supp.**



AP5100 **Page : 1**
Date : May 04, 2016 **Time :** 12:05 pm
Bank : 1 To 1
Status : All
Medium :
M=Manual C=Computer R=Credit E=EFT-PAP T=EFT-File

Supplier : 0050 To 912
Trans. Date : 01-Apr-2016 To 30-Apr-2016
Cheque Date : 01-Apr-2016 To 30-Apr-2016
Cheque No. : All
Batch No. : All

Supplier	Supplier Name					
Chq/Ref #	Cheque Date	Status	Batch	Medium	Amount	
Invoice No.	Account No.	Account Description		Debit	Credit	
1125	MUNICIPAL FINANCE AUTHORITY					
EFT-1	06-Apr-2016	Issued	8	E		5647.41
93-1/2016	01-4-6030-000	ACCOUNTS PAYABLE		5647.41		
Invoice Description --> DEBENTURE DEBT						
Total :				5647.41	0.00	5647.41
Supplier Total :				5647.41	0.00	5647.41

1850	VANCOUVER ISLAND HEALTH AUTHORITY					
1028	25-Apr-2016	Issued	6	C		448011.57
APR14/16	01-4-6030-000	ACCOUNTS PAYABLE		448011.57		
Invoice Description --> P760, P761, P806, P807, P808, E2-762, E1-809						
Total :				448011.57	0.00	448011.57
Supplier Total :				448011.57	0.00	448011.57

Total Computer Paid :	<u>448,011.57</u>	Total EFT PAP :	<u>5,647.41</u>	Total Paid :	<u>453,658.98</u>
Total Manually Paid :	<u>0.00</u>	Total EFT File Transfer :	<u>0.00</u>		